

nobonobo<sup>®</sup>







# NOBONOBO IS CREATED BY PEOPLE!<sup>IT</sup>

**WILL NOT WORK WITHOUT THEM.**

*NOBONOBO is a Polish brand created by people with passion, specialists, and masters in their field. Thanks to the company's long-time experience and craftsmanship, the quality has become the foundation of all that we do since the beginning of our existence. This is expressed, among others, by the rules that we follow, and by using the best materials available for the production. The upholstered furniture that we offer are being made in our factory in Łodygowice, which makes it possible to control even the smallest details and to care for each production stage. Our openness, passion, and commitment to what we do allow us to get ahead of the trends and set the direction on the Polish, and foreign markets, and the continuous expansion of our group of designers results in the creation of a new dimension of the global design, which is appreciated on a regular basis in numerous competitions. Thanks to that we know that, what we do makes sense, and encourages us to even more intensive development. Each day we set the bar very high, so that our products meet the expectations of the most demanding clients and architects, who expect excellent quality on the highest level. The furniture that we make can be found in selected Polish, and foreign showrooms.*



**DESIGN  
DLA KONESERA**  
PIĘKNO INNOWACJA PRESTIŻ

**Da**  
DESIGNALIVE.PL

**must  
have**





# OUR DESIGNERS



Tomek **RYGALIK**



Nelson **DE ARAÚJO**



Mleko **LIVING**



Ezio **PESCATORI**



Chris **STANFEL**



Dimitry **KOZINENKO**



Ewo **PÓLTORAK**



Juanny **BARCELÒ BORGES**



Sergey **MURKO**



Stas **LITVINOW**



**NOBONOBO LAB**

*Original designs of the best sort – being understood holistically - addressing each aspect of the products and services, have become Nobonobo's key pillar. We cooperate with a group of the best designers from all around the world, which expands on a regular basis by new, exceptional names.*



# IN LINE WITH NATURE

*The brand of Nobonobo, probably as the only one in the world, uses technical fabrics made exclusively for our own purposes from processed PET bottles. In 2021, while manufacturing our sofas, we recycled more than 1,000,000 PET bottles, and there will be more of them.*





# NATURAL FEATHERS



*In our sofas, we use specifically selected natural feathers, which are characterized by an exceptional elasticity and softness. With such a solution, we can obtain the highest comfort, which will be appreciated by even the most demanding users.*



# ITALIAN FABRICS

*Nobonobo offers an original collection of natural fabrics made of high quality fibers such as flax, cotton, and viscose. This is a collection right from Italy, dedicated to the Nobonobo brand exclusively, in which the colors of earth, loved by all, dominate.*





# INDEX

## SOFAS

Bola	130, 221
Duna	124, 222
Feza	100, 223
Lanube	58, 226
Margo	66, 228
Maxxo	40, 229
Most	108, 231
Paradise	116, 232
Raksa	82, 233
Umo	90, 236
Wadi	74, 238

## BEDS

Alier	154, 240
Piano	158, 241
Piero	150, 242
Skoro	142, 243
Violet	146, 244
Umo	138, 245

## ARMCHAIRS, CHAIRS

Pyora I	162, 248
Pyora II	162, 248
Tupak	170, 247
Margo	66, 228
Must	166, 247
Uni	46, 249

## ARMCHAIRS, CHAIRS

Ferro	200, 254
Feza	196, 254
Flesia	188, 255
Minus	192, 255
Nato	184, 255
Oo	178, 256
Roots	174, 256

## POUFS

Bunny Guys	52, 251
Modo	204, 251
Umo	98, 253
Wadi	74, 238

## OTHERS

Bamba	208, 258
Sad	212, 261

## TECHNICAL INFORMATION

Wymiary	217
---------	-----



*Nelson de Araújo has graduated from the Product Design Faculty. He discovered his passion for the furniture industry during his stay in Italy within the Erasmus programme at the Università degli Studi di Palermo. This experience has triggered the development of his critical sense and curiosity, by shaping his furniture designing vision. Nelson de Araújo pursues perfection in each product he designs.*

**MARGO**

66, 228

**ROOTS**

174, 256

# Nelson DE ARAÚJO





*A designer, a lecturer, an administrator, and a PhD of arts. He has studied architecture at the Technical University of Łódź. A graduate of the Industrial Design Faculty at the Pratt Institute in New York. In 2006, he founded Studio Rygalik, which promotes the conscious way of thinking in designing, supports sustainable development, responsible consumption of material goods and resources of our planet.*

# Tomek RYGALIK

<b>NATO</b>	184, 255
<b>OO</b>	178, 256
<b>RAKSA</b>	82, 233
<b>TUPAK</b>	170, 247
<b>WADI</b>	74, 238





*In 2016, Katarzyna Załuska and Michał Załuski graduated from the architecture faculty at the Technical University of Eindhoven. In 2017, they established the Mleko Living studio, in which they follow the philosophy of creating natural and simple products for daily use. Life becomes simpler and more conscious as a result of having a smaller number of things and selecting them carefully.*

**BAMBA**

208, 258

Mleko  
**LIVING**





*In 2012, he began designing rooms and products, and for the last 3 years he was focused mostly on designing furniture. Currently, he lives and works in Kiev in Ukraine. He spends a lot of time thinking about the visual side of life, and how it affects one's personality. He tries to create not only new things, but also design rules and patterns, which sometimes go beyond the product design area.*

**MINUS**

192, 255

# Dimitry **KOZINENKO**





*He has graduated from the product design faculty, first at the Technical University in Valencia, then at EASD, also in Valencia. Apart from designing small products, he is also interested in designing furniture, since, as he says, this is about dressing the space, where we usually live, and these spaces must make us feel comfortably. Chris loves it when a product has a personality, and talks to us, when we look at it.*

**FLESIA**

188, 255

Chris  
**STANFEL**





*A designer with more than 20 year of experience. He lives and creates in Lombardy in Italy. For many years, he has worked as the product development manager at international companies involved in the production of furniture for homes, bathroom furniture, shower cabins, and decorative lighting equipment. His imagination and curiosity are these features of his nature, which are most useful in the daily work of a designer.*

**SAD**

212, 261

# Ezio PESCATORI





She has always been passionate about creative work in the field of functional forms. Each project begins with an analysis and understanding of human needs, habits and lifestyle, so that the designed form introduces aesthetic harmony and greater user comfort into everyday life. She studied both in Poland and abroad, and gained her first experience working in an international team in Valencia.

**LANUBE**

58, 226

Ewa  
**PÓŁTORAK**



Juanny Barcelò Borges is a Cuban-Italian multidisciplinary designer based in Milan, Italy. Helping companies and open-minded individuals to build a meaningful future and value their unique story. The work always begins with the search for a fresh and eye-catching point of view, the search for an intuition which can be inspired by the materials, the technology, by the company or by the individual users. With particular attention to details and essential forms, in order to communicate the story, along with a good dose of playfulness and charm.

# Juanny **BARCELÒ BORGES**

**MAXXO**

40, 229





Designer and founder of the MURI brand, believes that creating furniture is an art. Sergey Murko graduated in law and economics, but it was design that was always close to his heart. For the last 14 years, he created furniture, giving people comfort and convenience. Today he knows that the path he took was not accidental. Today he also has a brand of his own, he uses to design and create. It is very important for him to be able to build a piece of furniture that he himself invented and designed. The creative process itself is one of the sources of his satisfaction, as he enjoys touching materials, shaping wood, or getting his hands dirty with glue. Designing and creating are his real passion and his whole life.

Sergey Murko Kyiv Ukraine

# Sergey MURKO

**BUNNY GUYS**

52, 251



Stas Litvinov Studio is a design studio that offers simple and honest design. In its projects, they are guided by the maxim that the product should be what it was created for. An armchair or a large sofa should be used to rest, to lie down. They believe that in the contemporary world of consumerism, products should be created that deserve the right to exist, and as long they fail to fit into temporary trends, they have the potential to become timeless classics.

# Stas LITVINOV

UNI

46, 249





*The Nobonobo Lab is formed by experienced and very committed people. It is a team of process engineers, specialists, and craftsmen with long-time experience in the furniture industry. Work in such a group translates into the creation of extremely comfortable and ergonomic furniture, which are offered by Nobonobo.*

# NOBONOBO LAB

<b>ALIER</b>	154, 240	<b>PARADISE</b>	116, 232
<b>BOLA</b>	130, 221	<b>PIANO</b>	158, 241
<b>DUNA</b>	124, 222	<b>PIERO</b>	150, 242
<b>FEZA</b>	100, 223	<b>PYORA</b>	162, 248
<b>FEZA TABLE</b>	196, 254	<b>SKORO</b>	142, 243
<b>FERRO</b>	200, 254	<b>UMO</b>	90, 236
<b>MODO</b>	204, 251	<b>UMO BED</b>	138, 245
<b>MOST</b>	108, 231	<b>UMO POUF</b>	98, 251
<b>MUST</b>	166, 247	<b>VIOLET</b>	146, 244

# MAXXO

It is defined by its strong, architectural solid, which balances between attention focused on enhanced armrests and light metal legs that support this massive solid above the ground. The designer managed to maintain the right proportions, at the same time ensuring a perfect balance of style and comfort. The splendor is further enhanced by geometric lines of handmade tailoring.





# MAXXO

## TYPE

non-folding

## FILLING

flexible stripes

SoftLayers™ system – a composition of specially selected flexible foams to ensure the best comfort

selected natural feathers of high elasticity class / possible replacement with antiallergic filling

## LEGS

metal black matt / chrome

\* technical information p. 229



LEGS



black mat



chrom





# UNI

The UNI armchair has all the attributes of a good design: it is comfortable to sit on, easy to keep clean, durable and at the same time made of recyclable materials. UNI is a universal and multi-purpose armchair, that will fit apartments, country houses, cafes and offices. It will also work great on a terrace or in the garden. You can get up from it comfortably, but to tell you the truth, you will be reluctant to do so.



# UNI

## FILLING

Polystyrene + polyester silicone fibers. Our fibers have an air channel and are additionally torsionally crimped, which provides the product with spaciousness, fluffiness and elasticity.

## LEGS

metal black matt  
RAL 9010

\* technical information p. 249

LEGS



black matt



9010 RAL



photo - Stas Litvinov







# BUNNY GUYS

Bunny Guys is a friendly and timeless project that will give character to every interior it is placed in. This rabbit can create a unique and charming mood in its surroundings, depending on the fur it will wear. In the living room or in the children's room, it will create a cozy and fairy-tale atmosphere, while in a public space it will be a charming accent, which no one will pass indifferently. There may be one or more. The effect will always be surprising.





# BUNNY GUYS

## FILLING

SoftLayers™ system – a composition of specially selected flexible foams to ensure the best comfort

selected natural feathers of high elasticity class / possible replacement with antiallergic filling

## LEGS

solid oak wood, black color

\* technical information p. 251

LEGS



black









# LANUBE

The Lanube collection, inspired by the beauty of nature that surrounds us, the change of seasons, days and moods, is a fresh vision of a modular sofa. Designed to create a space for relaxation, spending time together, sharing moments and living. Simple and soft forms, and at the same time ample modules, invite you to create endless compositions and immerse yourself in their extraordinary comfort. Lanube, refined to the touch, with delicate details perfectly integrated with the forms, creates additional functionalities, thanks to which the sofa can be integrated into almost any interior.









# LANUBE

## TYPE

non-folding

## FILLING

flexible stripes

SoftLayers™ system – a composition of specially selected flexible foams to ensure the best comfort

## BACKREST PILLOWS

Selected natural feathers of high elasticity class/ possible replacement with anti-allergic filling

## LEGS

solid oak wood, black color

\* technical information p. 226

LEGS



black







# MARGO

*The Margo collection designed by Nelson de Araújo has been inspired by the autumn in Portugal and a fascinating farewell to the summer. The autumn is the calmest season, the sun is lower in the sky, birds migrate to warmer places, natural greenery turns yellow, orange, red, and bronze, and warm shades take over the natural landscapes. The nature slowly prepares to colder days.*









# MARGO

## TYPE

non-folding

## FILLING

flexible stripes

SoftLayers™ system – a composition of specially selected flexible foams to ensure the best comfort

selected natural feathers of high elasticity class / possible replacement with antiallergic filling

## FRAME

solid beech wood

## ADDITIONAL OPTIONS

sofa is available with or without pillows

\* technical information p. 228

## FRAME



scandinavian



walnut



ebony



black



photo - Nelson de Araújo







# WADI

*Wadi collection includes a double and triple sofa, an armchair and a pouf. Regardless of the space, Wadi will not dominate it and will become a distinctive element of the interior. Its characteristic form consists of a combination of narrow modules. It is super comfortable and the covers are removable for maintenance. Wadi collection is designed and produced within the circular economy model and has been recognised with prestigious awards – Must Have 2020 and Good Design 2020.*







photo - Yassen Hristov  
interior design - POCO Design, Patrycja Suszek-Rączkowska



# WADI

## TYPE

non-folding

## FILLING

SoftLayers™ system – a composition of specially selected flexible foams to ensure the best comfort

selected natural feathers of high elasticity class / possible replacement with antiallergic filling

## FRAME

metal, mat black color

\* technical information p. 238

**must  
have**



photo - Yassen Hristov  
interior design - POCO Design, Patrycja Suszek-Rączkowska





photo - Yassen Hristov



# RAKSA

*Raksa designed by Tomek Rygalik with its plain form and refined proportions is a super comfortable modular sofa with a timeless line. The backrest is harmoniously composed of large cushions. It consists of soft modules enabling many configurations, and includes a table module veneered in timeless, elegant oak or American walnut. Raksa is available in two versions with different depths, to enhance the feeling of comfort, and adapt its standard to individual needs. Designed with sustainability and ease of maintenance in mind, Raksa's upholstery can be completely removed.*









# RAKSA

## TYPE

non-folding

## FILLING

flexible stripes

SoftLayers™ system – a composition of specially selected flexible foams to ensure the best comfort

selected natural feathers of high elasticity class / possible replacement with antiallergic filling

## LEGS

solid oak wood, black color

## BACKREST PILLOWS

selected natural feathers of high elasticity class / possible replacement with antiallergic filling

\* technical information p. 233

SHELF



OAK VENEER



BLACK OAK VENEER



AMERICAN WALNUT



photo – Yassen Hristov







# UMO

*The Umo sofa will charm for enthusiasts of modern and minimalist forms, who expect comfort and convenience. It has a modular design, which gives broad opportunities of adapting the furniture as necessary. This opens almost unlimited possibilities of configuring the furniture's layout, and creating a true island of leisure in any living room. One decoration of this sofa is its exposed sewing, which enhances its style. Umo is a typical lazybones, who invites to rest and relax with its design.*







# UMO

## TYPE

non-folding

## FILLING

flexible stripes

SoftLayers™ system – a composition of specially selected flexible foams to ensure the best comfort

selected natural feathers of high elasticity class / possible replacement with antiallergic filling

## LEGS

solid oak wood, black color

\* technical information p. 236



photo - Bartek Bielinski Fotografia  
interior design - Architektura wnetrz Anna Thuraw







# UMO POUF

**TYP**  
folding

**MATTRESS**  
foam, height 10 cm

\* technical information p. 252



# FEZA

*The Feza modular sofa has a universal industrial design, this is why it matches any interior design, from those modern to those classic ones. Its design and high quality deserve special attention. The sofa is supported on metal legs that perfectly balance the wide and, at the same time, comfortable seats finished with precise seams. The sofa can be configured freely, since many different modules are available. Feza is the winner of the prestigious 2018 Design dla Konesera award.*









# FEZA

## TYPE

non-folding

## FILLING

flexible stripes

SoftLayers™ system – a composition of specially selected flexible foams to ensure the best comfort

selected natural feathers of high elasticity class / possible replacement with antiallergic filling

## LEGS

metal, black mat

\* technical information p. 223

**DESIGN**  
DLA KONESERA  
PIĘKNO INNOWACJA PRESTIŻ

### SHELF



OAK WOOD



OAK VENEER



BLACK OAK VENEER



AMERICAN WALNUT



EKO-LEATHER



photo - Marek Swoboda Fotografia  
interior design - Kubieniec & Długosz





# MOST

*The Most sofa is distinguished mainly by its unprecedented style. Delicate quilts and loose backrest cushion filling give the effect of a soft, extremely comfortable sofa adapted to the needs of the present market. The Most sofa is supported by metal legs shaped like a bridge, hence the name of this model. Most won the prestigious Design dla Konesera award in 2019.*









# MOST

## TYPE

non-folding

## FILLING

flexible stripes

SoftLayers™ system – a composition of specially selected flexible foams to ensure the best comfort

selected natural feathers of high elasticity class / possible replacement with antiallergic filling

## BACKREST PILLOWS

selected natural feathers of high elasticity class / possible replacement with antiallergic filling

## LEGS

metal, black mat, chrom

\* technical information p. 231

**DESIGN**  
DLA KONESERA  
PIĘKNO INNOWACJA PRESTIŻ









# PARADISE

*Paradise is a modern sofa, which combines luxury and elegance. Those who appreciate comfort will like it. Its deep seat combined with its soft, feather backrest pillows, guarantees the best relaxation and leisure. The sofa is supported on solid oak wood legs, synonymous with strength and durability. Such a solution gives the sofa its lightness and delicate form. Paradise is a timeless model, perfect both for classical and modern rooms.*









# PARADISE

## TYPE

non-folding

## FILLING

flexible stripes

SoftLayers™ system – a composition of specially selected flexible foams to ensure the best comfort

selected natural feathers of high elasticity class / possible replacement with antiallergic filling

## LEGS

solid oak wood

## BACKREST PILLOWS

selected natural feathers of high elasticity class / possible replacement with antiallergic filling

\* technical information p. 232

## LEGS



natural



brown  
22-51



brown  
22-55



black  
29-10



photo - Tomasz Miotk Fotografia  
interior design -Mozayka nieruchomości i projektowanie, Polala Studio







# DUNA

*Duna is a Scandinavian style sofa, which is functional, simple, and minimalist. Duna's steel structure is supported on solid oak wood legs, giving the sofa its lightness and character. With its simple form free from unnecessary decorations, it will match the taste of those who like minimalist and modern designs, who expect their furniture to be comfortable and functional. With its rapid un-folding system, the sofa can turn into a large and comfortable sleeping bed anytime.*





# DUNA

## TYPE

folding

## FILLING

flexible stripes,

SoftLayers™ system – a composition of specially selected flexible foams to ensure the best comfort

## LEGS

solid oak wood

## FRAME

metal, mat black color

\* technical information p. 222

## LEGS



natural



brown  
22-51



brown  
22-55



black  
29-10







# BOLA

*The Bola sofa features a modern design combined with practicality and functionality. It is available in both a non-folding, and a folding version. The sleeping function is the sedaflexsystem, equipped with a foam mattress with a height of 10 cm, it is intended for naps. Bola is a convenient and comfortable sofa, among others thanks to its ergonomic backrest, which fits the person sitting on it perfectly. The modern style, and carefully designed details, which characterize this model, will satisfy the needs of even the most demanding enthusiasts of the contemporary industrial design. One detail distinguishing this sofa is its special pocket sewing, used to finish the sofa's sides and backrest.*









# BOLA

## TYPE

non-folding / folding

## FILLING

flexible stripes,

SoftLayers™ system – a composition of specially selected flexible foams to ensure the best comfort,

selected natural feathers of high elasticity class / possible replacement with antiallergic filling

## LEGS

solid oak wood, black color

\* technical information p. 221



photo - Studio Prototypownia Alla Boroń  
interior design - Dobry Układ Sandra Białkowska







# UMO

*Umo is a bed model that perfectly matches modern bedrooms. The model's coherent appearance is ensured by its simple geometric form emphasized by decorative exposed seams. The loose fabric, along with the filling, give the Umo bed its soft appearance, which is the best invitation for rest. The model is equipped with a box for bed linen.*



# UMO

## TYPE

with a bedding container

## OPTION

the bed frame is available in 2 versions:  
for self assembly or assembled

\* technical information p. 245





# SKORO

*The Skoro bed is a great proposal for enthusiasts of modern interiors. The model has an interestingly designed headrest with two pillows resting on it. They ensure soft support during reading or watching films. The frame of the bed is also softly upholstered. The Skoro model is a direct invitation to blissful leisure.*



# SKORO

## TYPE

without a bedding container

## OPTION

the bed frame is available in 2 versions:  
for self assembly or assembled

## LEGS

solid oak wood

\* technical information p. 243



## LEGS



natural



brown  
22-51



brown  
22-55



black  
29-10



# VIOLET

*The Violet bed has a definite nature, which makes it the most attractive element in the bedroom. It is an offer for persons looking for original solutions. And all this results from the decorative frill that surrounds the frame and the headrest. The whole is supported on round legs made from solid oak wood.*



# VIOLET

## TYPE

without a bedding container

## OPTION

the bed frame is available in 2 versions:  
for self assembly or assembled

## LEGS

solid oak wood

\* technical information p. 244

### LEGS



natural



brown  
22-51



brown  
22-55



black  
29-10





# PIERO

*Piero, a modern upholstered bed, is a model with a soul. A wide headrest covers the mattress, creating the pleasant sense of coziness. This is intensified by softly upholstered fabrics pleasant to the touch, with interesting natural wrinkles. The base of this bed is formed by a wooden frame and legs made from solid beech wood.*



# PIERO

## TYPE

without a bedding container

## OPTION

the bed frame is available assembled

## LEGS / FRAME

solid beech wood

\* technical information p. 242

### LEGS, FRAME



scandinavian



walnut



ebony



black





# ALIER

*The Alier bed is a classic offer for bedrooms – elegant in its simplicity. One interesting detail is its precisely made trimmings that match the upholstery color. The model has a container for bed linen, which provides an additional storage place.*



# ALIER

## TYPE

with a bedding container

## OPTION

the bed frame is available in 2 versions:  
for self assembly or assembled

\* technical information p. 240





# PIANO

*The Piano upholstered bed is a model that can be distinguished by its loosely sewn cover that rests freely on the robust structure. The whole is complemented by details in the form of decorative knots on a soft and comfortable headrest. The model is intended for persons who like wrinkling and naturally creased, loose materials. These are the features that give the proper tone to the whole. An additional advantage is a large container for bed linen.*



# PIANO

## TYPE

with a bedding container

## OPTION

the bed frame is available in 2 versions:  
for self assembly or assembled

\* technical information p. 241





# PYORA

*Pyora is an armchair in two options that perfectly match modern interiors. Pyora I is the version supported on an elegant, chrome-plated rotating foot, so it can be called a business armchair. Pyora II is the club version, perfect both for a contemporary living room, and for a hotel lobby. Regardless of the type of the room, the Pyora armchair makes it more welcoming, without affecting its elegance.*



# PYORA

## **TYPE**

swivel leg

## **FILLING**

flexible stripes

SoftLayers™ system – a composition of specially selected flexible foams to ensure the best comfort

selected natural feathers of high elasticity class / possible replacement with antiallergic filling

## **BACKREST PILLOW**

selected natural feathers of high elasticity class / possible replacement with antiallergic filling

## **LEG PYORA I**

metal, chrome color

## **LEG PYORA II**

metal, grey color

\* technical information p. 248





# MUST

A comfortable chair is synonymous with comfort and good design. Craftsmanship and care are also evident in the MUST chair. The solid beech base combined with an upholstered seat and backrest are as comfortable as they are pleasing to the eye.



# MUST

## LEGS

solid beech wood

\* technical information p. 247

## LEGS



scandinavian



walnut



ebony



black





# TUPAK

*Tupak armchair is characterised by its organic form and comfortable backrest gently surrounding the user, with a visually integrated lumbar pillow. Tupak has a stable, wooden structure on rounded legs. The wooden base emphasizes the form of the seat, which together with the backrest is softly upholstered assuring the best comfort.*



# TUPAK

## LEGS

solid beech wood

\* technical information p. 247

## LEGS



scandinavian



walnut



ebony



black





# ROOTS

*The Roots table is a combination of organic shapes and natural motion. Created for courageous people, who like the minimalist style. When designing the Roots table, Nelson de Araújo was inspired by curved natural shapes – ocean waves, clouds in the sky, a flowing river, and the roots of trees that grow freely underground. The designer's goal was to move the nature from the environment outside into homes.*





# ROOTS

## TABLE TOP

solid oak wood

## LEGS

powder coated metal

\* technical information p. 254

### TABLE TOP, LEGS



natural

brown  
22-51

brown  
22-55

black  
29-10



RAL BLACK  
MAT

RAL 7024

RAL 8022

RAL 6011

RAL 1013





# OO

*Oo collection designed by Tomek Rygalik consists of round tables of different sizes and heights. Three types are available: a dining table intended for residential interiors, a cafe table, dedicated for commercial premises and coffee table. Their distinctive detail is the ring surrounding the metal base. The tabletops feature a soft, rounded bottom edge and are veneered with elegant and timeless oak or American walnut. The collection allows for creating diverse interior arrangements.*





COFFE TABLE  
CAFE TABLE  
DINING TABLE

**TABLE TOP**  
oak veerner, american walnut

**LEGS**  
powder coated metal

\* technical information p. 256

TABLE TOP, LEGS



OAK VENEER



BLACK OAK VENEER



AMERICAN WALNUT



RAL BLACK MAT



photo - Yassen Hristov





# NATO

*Nato collection is characterised by three distinctive tabletop shapes – oval, stadium and squoval. The tops have a soft, rounded bottom edge and are veneered with elegant and timeless oak or American walnut. The table can be easily cantilevered over the sofa seat, increasing the functionality and supporting the comfort of use. While relaxing on the sofa, Nato table can serve as a suitable place for a book, laptop or a cup, within an easy reach.*





# NATO

## TABLE TOP

oak veneer, american walnut

## LEGS

powder coated metal

\* technical information p. 255

### TABLE TOP, LEGS



OAK VENEER



BLACK OAK VENEER



AMERICAN WALNUT



RAL BLACK MAT



photo - Yassen Hristov

# FLESIA

*The Flesia coffee tables have been designed by Spanish designer Chris Stanfel in cooperation with the EASD School of Design in Valencia. The design reflects an exotic appearance, which is based on rafflesia – a characteristic plant from the islands of Indonesia. Its five legs upholstered with bright colors bring the large flakes of its flower to one's mind. This collection of organic shapes undoubtedly breaks the schemes, and cannot be just ignored.*





# FLESIA

**TABLE TOP**  
solid oak wood

**LEGS**  
upholstered element

\* technical information p. 255

TABLE TOP



natural



brown  
22-51



brown  
22-55



black  
29-10



# MINUS

*Dimitry Kozinenko has combined the two halves of a small table, by inserting a piece of oak between them, in order to bring the warmth of wood into this design. If we look from above, this wooden element reminds the „minus” sign, and this is the origin of the series’ name. The collection consists of four small tables, thus different sizes and colors can be composed.*





# MINUS

## TABLE TOP

*powder coated aluminum sheet*

## LEGS

powder coated metal

## DETAIL

solid oak wood

\* technical information p. 255

TABLE TOP, LEGS



RAL WHITE MAT



RAL BLACK MAT



other colors



# FEZA

*The Feza small table collection is based on a metal structure having the shape of a spider's legs joined with a table-top made of solid oak wood. The phased table top mirrored at an angle is perfectly combined with the legs of the base, resulting in a unique, complete shape. The table is available in three different shapes, to give a character and individuality to a room.*





# FEZA

**LEGS**  
powder coated metal

**TABLE TOP**  
solid oak wood

\* technical information p. 254

TABLE TOP, LEGS



natural    brown 22-51    brown 22-55    black 29-10



RAL BLACK MAT



# FERRO

*The Ferro small tables are characterized by a modern, minimalist style. They're made of high quality metal, functional, and, in addition, perfectly match almost any room.*





# FERRO

**TRAY**  
powder coated aluminum tray

**LEGS**  
powder coated metal

\* technical information p. 254

TRAY, LEGS



RAL WHITE MAT



RAL BLACK MAT



# MODDO

The Moddo pouffe is both comfortable and practical. It won the hearts of modern design enthusiasts immediately. It is filled with millions of elastic balls, and perfectly fits the human body





# MODO

**FILLING**  
granules

\* technical information p. 251



# BAMBA

The Bamba rack system has been designed by Mleko Living design bureau. The model is intended for residential, and office rooms. It consists of eight elements, which, when assembled, form a uniform and compact structure. The steel frame is robust, and stable. The shelves are available in two variants – wooden with natural veneer, and steel with a raised edge. Three feet lengths make it easier to create different configurations. What's important, the installation is easy and requires no tools. Therefore, we can change the arrangement of the shelves, or add new ones at any time. The model won the prestigious Must Have award in 2020.





# BAMBA

## MATERIAL

powder coated metal  
oak veneer, american walnut

\* technical information p. 258

**must  
have**  
SELECTED BY LAKE BOON FURNITURE 2017

## MATERIAL



OAK VENEER



AMERICAN WALNUT  
VENEER



RAL WHITE MAT



RAL 8022 MAT



RAL BLACK MAT



# SAD

The SAD wall hanger designed by Ezio Pescatori charms with its simple form. SAD is composed of two parts – a disk made from oak wood, and a metal part bent like a corner of a paper sheet, or a sticker that is flaking off. Single pieces may be freely combined with each other, to create different color and geometric arrangements. The designer has named it deceitfully SAD, despite the fact the hanger can become a merry element of the interior decor.





# SAD

## MATERIAL

solid oak wood,  
powder coated metal

\* technical information p. 261

## MATERIAL



SOLID OAK WOOD



RAL 9003  
MAT



RAL 7045  
MAT



BLACK MAT



# **TECHNICAL INFORMATION**



**SOFAS**

Bola	130, 221
Duna	124, 222
Feza	100, 223
Lanube	58, 226
Margo	66, 228
Maxxo	40, 229
Most	108, 231
Paradise	116, 232
Raksa	82, 233
Umo	90, 236
Wadi	74, 238

**BEDS**

Alier	154, 240
Piano	158, 241
Piero	150, 242
Skoro	142, 243
Violet	146, 244
Umo	138, 245

**ARMCHAIRS, CHAIRS**

Pyora I	162, 248
Pyora II	162, 248
Tupak	170, 247
Margo	66, 228
Must	166, 247
Uni	46, 249

**TABLES**

Ferro	200, 254
Feza	196, 254
Flesia	188, 255
Minus	192, 255
Nato	184, 255
Oo	178, 256
Roots	174, 256

**POUFS**

Bunny Guys	52, 251
Modo	204, 251
Umo	98, 253
Wadi	74, 238

**OTHERS**

Bamba	208, 258
Sad	212, 261

# SOFAS

# BOLA

\* All offered elements can be order in he left or right option

Technical information Sofa BOLA (mm)					
1	Total high	800	6	Armrest width	250
2	Seat height	420	7	Total depth	1040
3	Backrest height	-	8	Seat depth	650
4	Armrest height	560	9	Sleeping area - seat 1	1130-1830
5	Sleeping area : sofa 1, sofa 2, sofa 3, siedzisko 2, seat 3	1330-1830	10	Legs height	40

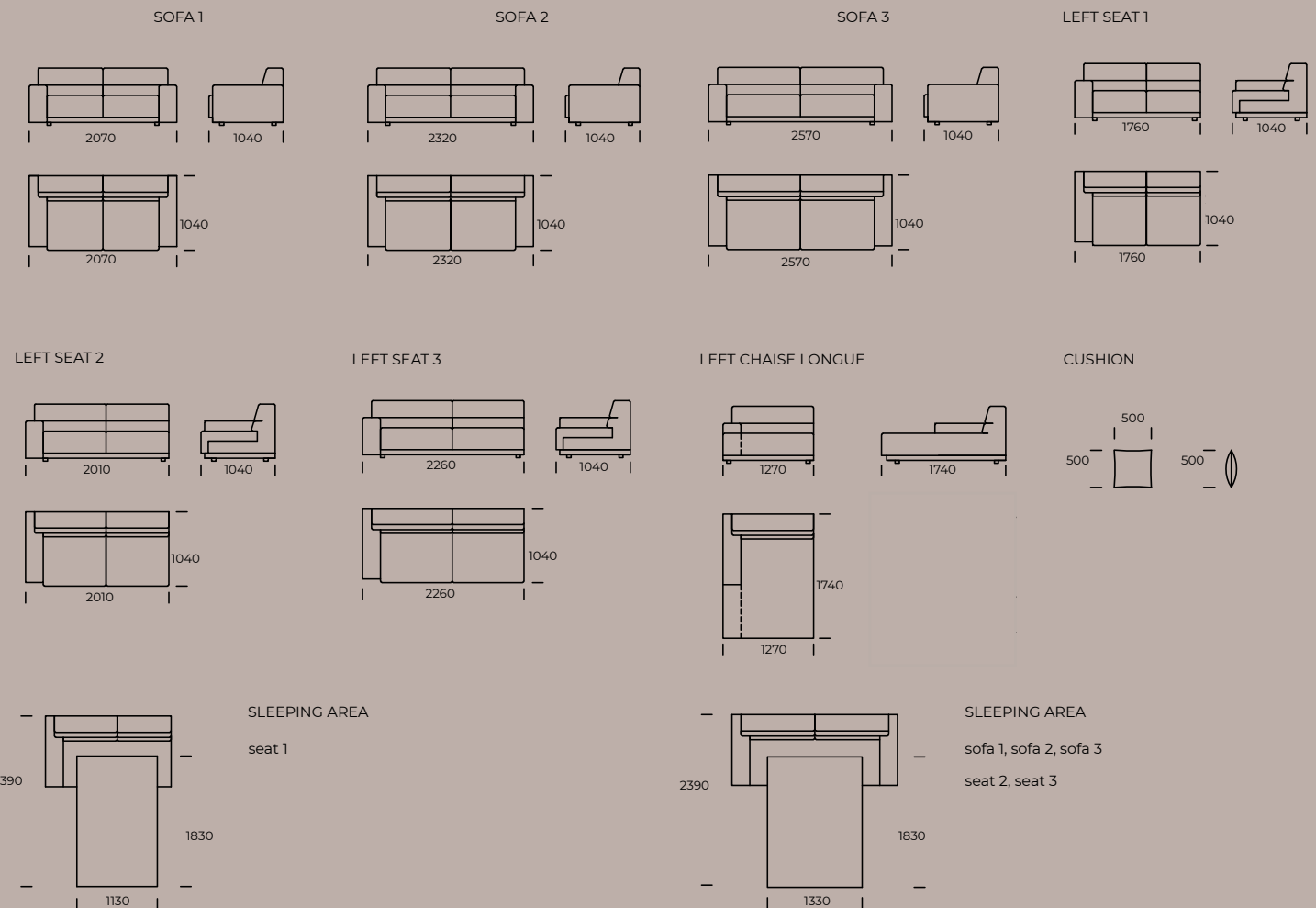



# DUNA

\* All offered elements can be order in he left or right option

Technical information Sofa DUNA (mm)					
1	Total high	880	6	Armrest width	190
2	Seat height	380	7	Total depth	1080
3	Backrest height	-	8	Seat depth	550
4	Armrest height	570	9	Sofa - Sleeping area	1450x2000
5	Corner - Sleeping area	1450x1930	10	Legs height	180

SOFA

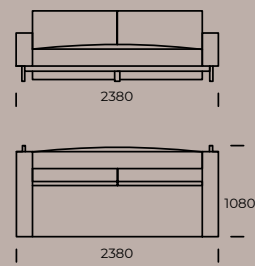

SOFA, UNFOLDED

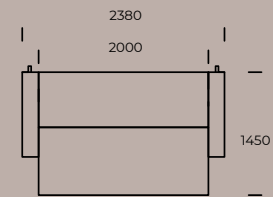

CORNER SOFA

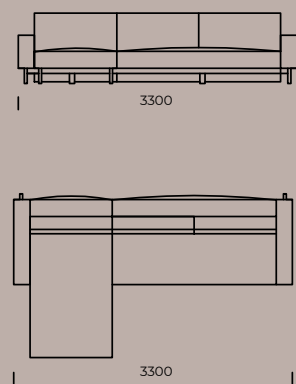

CORNER SOFA, UNFOLDED

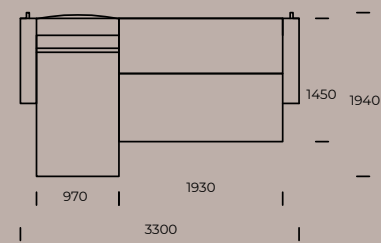

# FEZA

\* All offered elements can be order in he left or right option

Technical information Sofa FEZA (mm)					
1	Total high	790	5	Shelf width	340
2	Seat height	420	6	Total depth	960
3	Armrest narrow (h x w)	620/230	7	Seat depth	650
4	Armrest wide (h x w)	570/340	8	Legs height	140

SOFA A1



SOFA A2

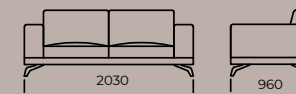

SOFA A3

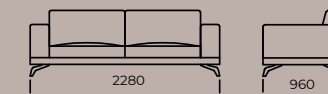

The sofa A1/A2/A3 is equipped with narrow armrests

SOFA B1

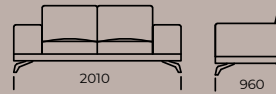

SOFA B2

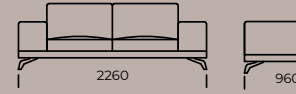

SOFA B3

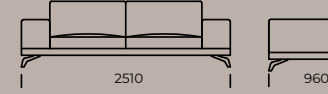

The sofa B1/B2/B3 is equipped with wide armrests

SOFA C1 - right shelf

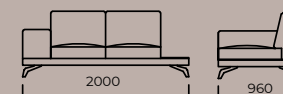

SOFA C2 - right shelf

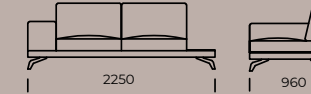

SOFA C3 - right shelf

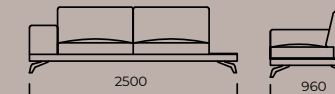

The sofa C1/C2/C3 is equipped with wide armrest and a shelf

# FEZA

\* All offered elements can be order in he left or right option

LEFT SEAT A1

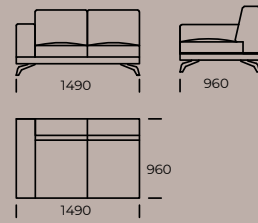

LEFT SEAT A2

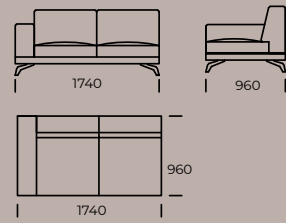

LEFT SEAT A3

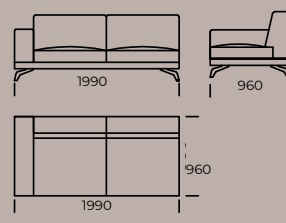

The seat A1/A2/A3 is equipped with narrow armrest

LEFT SEAT B1

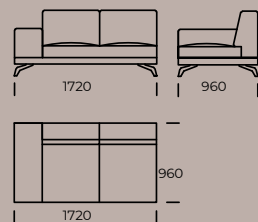

LEFT SEAT B2

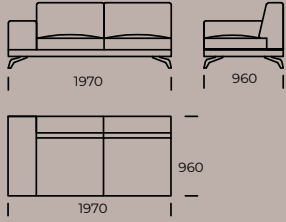

LEFT SEAT B3

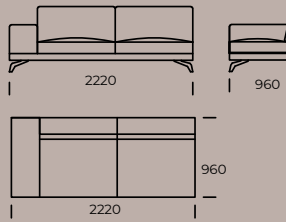

The seat B1/B2/B3 is equipped with wide armrest

LEFT SEAT C1

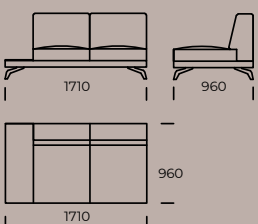

LEFT SEAT C2

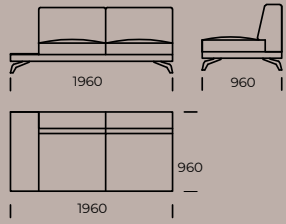

LEFT SEAT C3

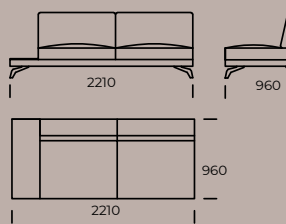

The seat C1/C2/C3 is equipped with a shelf

LEFT CHAISE LONGUE A1

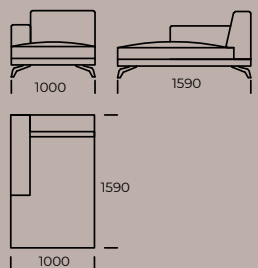

LEFT CHAISE LONGUE A2

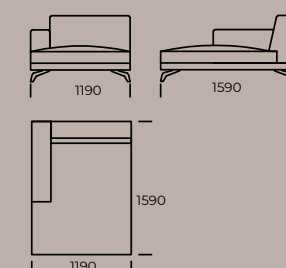

LEFT CHAISE LONGUE A3

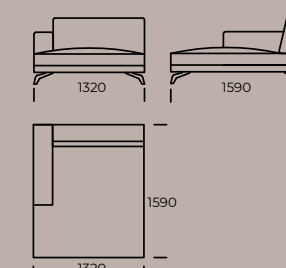

The chaise longue A1/A2/A3 is equipped with narrow armrest

# FEZA

\* All offered elements can be order in he left or right option

LEFT CHAISE LONGUE B1

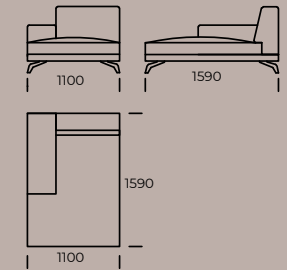

LEFT CHAISE LONGUE B2

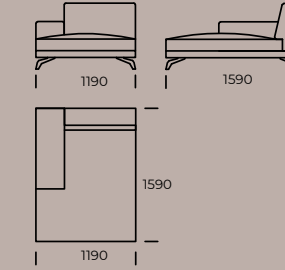

LEFT CHAISE LONGUE B3

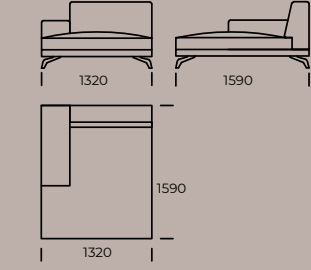

LEFT COUCH A

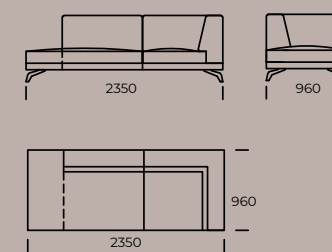

LEFT COUCH B

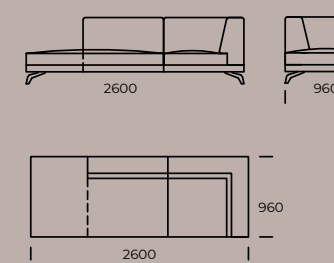

CORNER SEAT

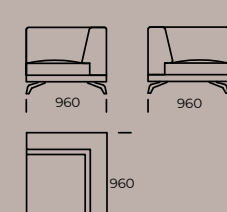

CENTRAL SEAT 1

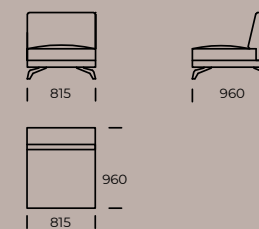

CENTRAL SEAT 2

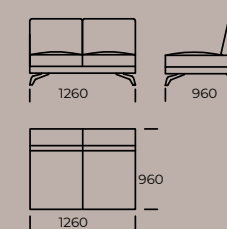

CENTRAL SEAT 3

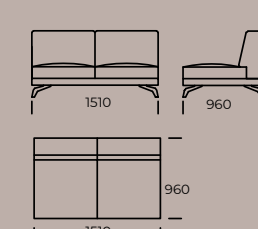

CENTRAL SEAT 4

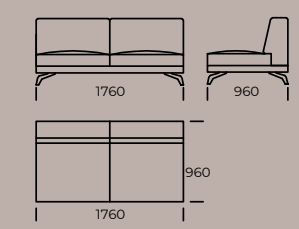

POUF



CUSHION

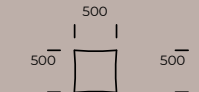

LUMBAR PILLOW



Cushion 5 cm narrower on each side of the backrest depending on the model chosen



# LANUBE

\* Wszystkie oferowane produkty można zamówić w formie odbicia lustrzanego

Wymiary techniczne Sofa LANUBE (mm)					
1	Wysokość całkowita	~850	5	Szerokość podłokietnika	160
2	Wysokość siedziska	390	6	Głębokość całkowita	1150-1950
3	Wysokość nógzek	40	7	Głębokość siedziska	800-1600
4	Wysokość podłokietnika	510	8	Powierzchnia spania	-

SIEDZISKO CENTRALNE 1

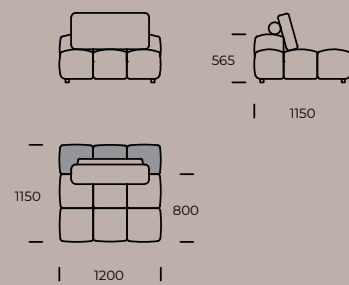

SIEDZISKO CENTRALNE 2

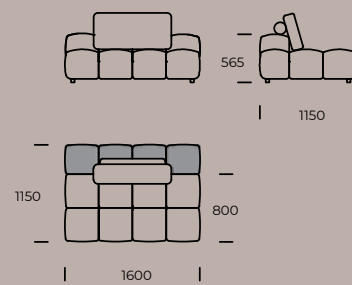

SIEDZISKO CENTRALNE 3

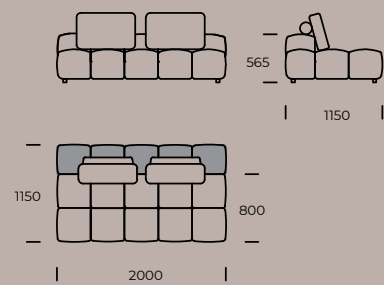

SIEDZISKO CENTRALNE 4

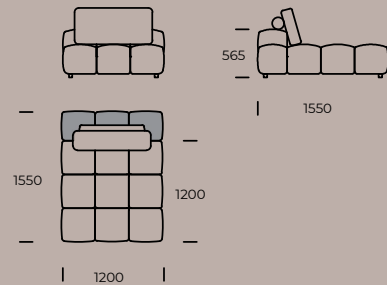

SIEDZISKO CENTRALNE 5

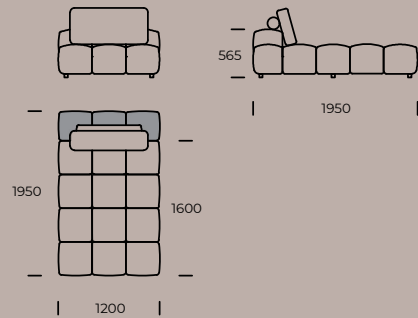

SIEDZISKO CENTRALNE 6

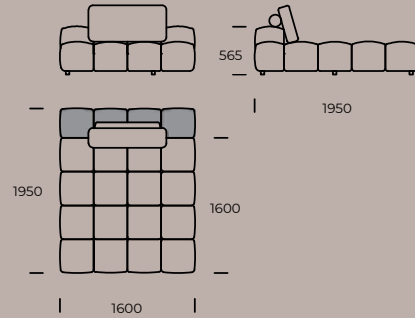

SIEDZISKO NAROŻNE 1 LEWE

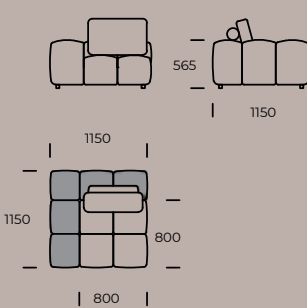

SIEDZISKO NAROŻNE 2 LEWE

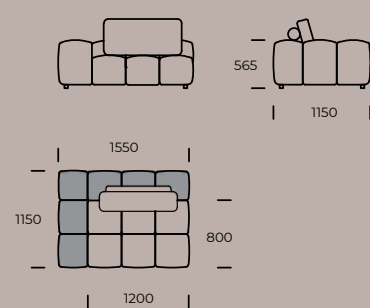

SIEDZISKO 1 LEWE

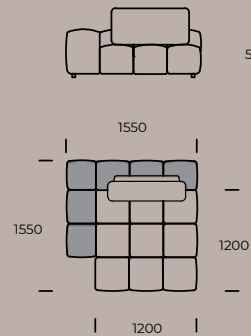

SIEDZISKO 2 LEWE

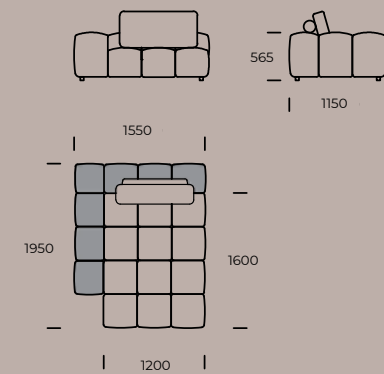

# LANUBE

\* Wszystkie oferowane produkty można zamówić w formie odbicia lustrzanego

PÓŁWYSEP 1 PRAWY

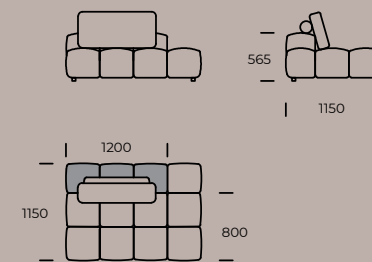

PÓŁWYSEP 2 PRAWY

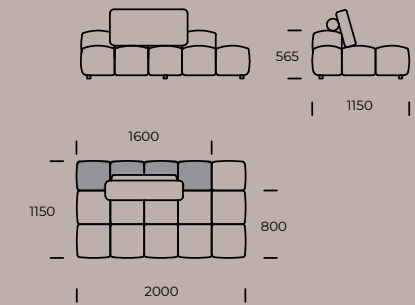

PUF 1

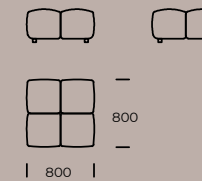

PUF 2

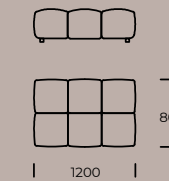

PUF 3

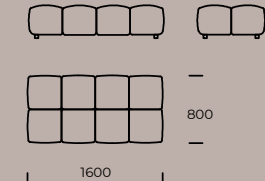

PODŁOKIETNIK

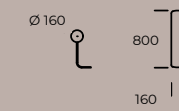

STOLIK

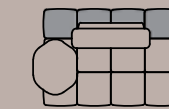
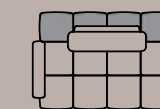
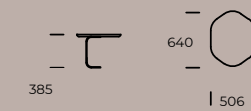

# MARGO

\* All offered elements can be order in he left or right option

Technical Information MARGO (mm)					
1	Total height	710	4	Total depth	820
2	Seat height	380	5	Seat depth with cushions	650
3	Armrest width	1120	6	Legs height	40

SOFA 1

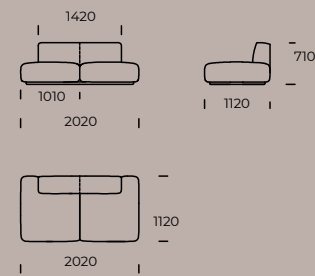

SOFA 2

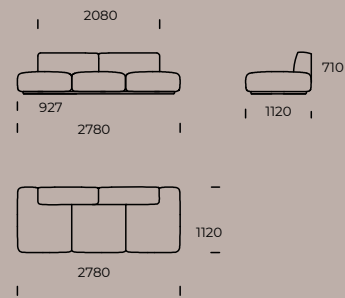

ARMCHAIR

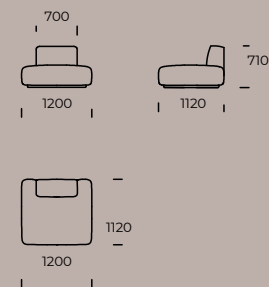

# MAXXO

\* All offered elements can be order in he left or right option

Technical information Sofa MAXXO (mm)					
1	Total high	750	6	Cushion height	-
2	Seat height	380	7	Total depth	1020
3	Backrest height	-	8	Seat depth	740
4	Armrest height	510 - 550	9	Legs height	150
5	Armrest width	380	10	Sleeping area	-

LEFT SEAT 1

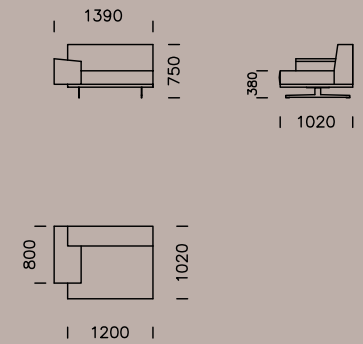

LEFT SEAT 2

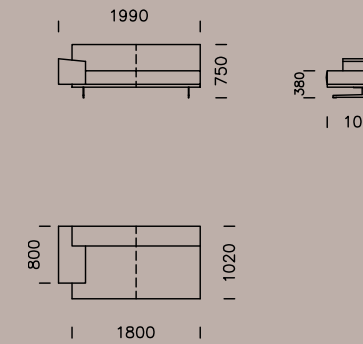

LEFT SEAT 3

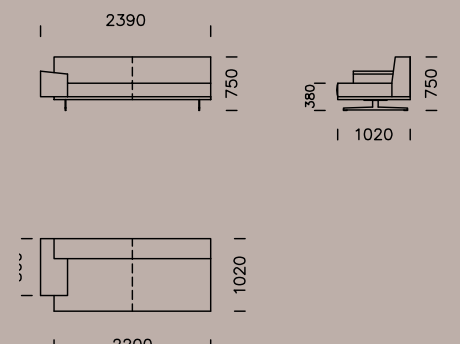

BACKREST SOFA MODULE

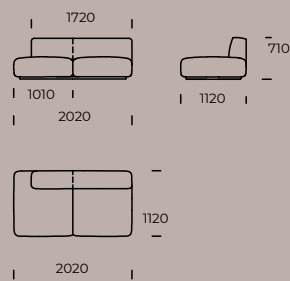

LEFT CHAISE LONGUE

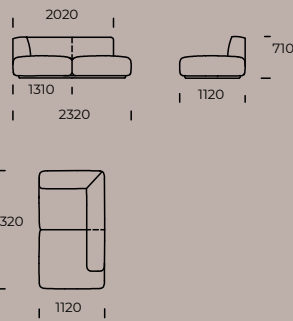

POUF



CENTRAL SEAT 1

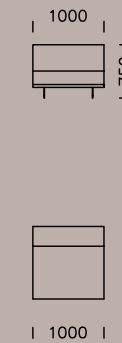

CENTRAL SEAT 2

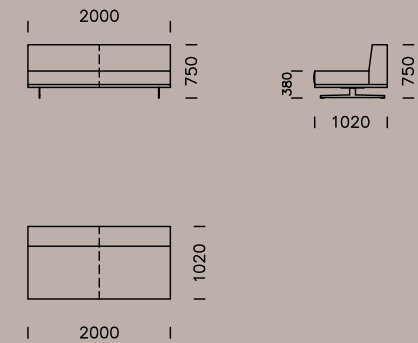

OPTION WITHOUT - WITH PILLOWS





# MAXXO

\* All offered elements can be order in he left or right option

LEFT CHAISE LONGUE 1

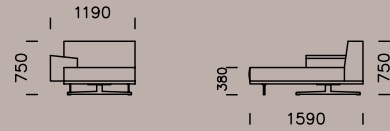

LEFT CHAISE LONGUE 2

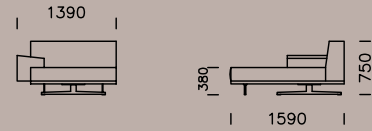

POUF

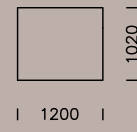
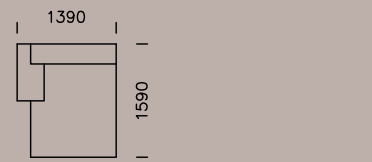
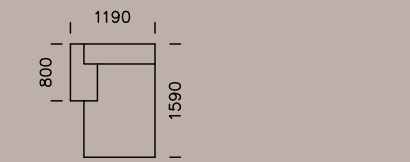

SOFA 1

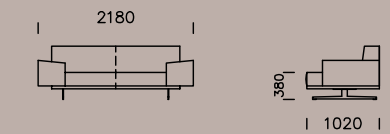

SOFA 2

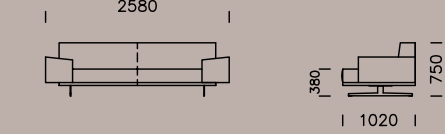

SOFA 3

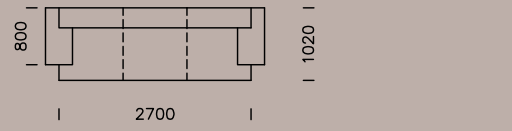
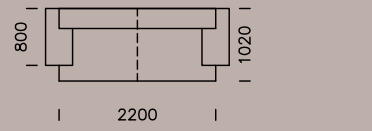
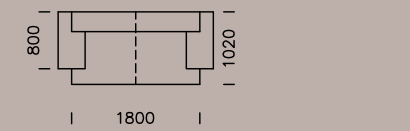
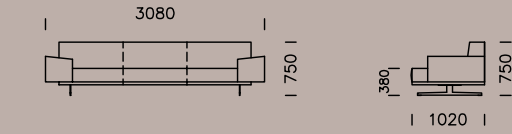

# MOST

\* All offered elements can be order in he left or right option

Technical information Sofa MOST (mm)					
1	Total high	920	6	Cushion height	600
2	Seat height	380	7	Total depth	1050
3	Backrest height	600	8	Seat depth	670
4	Armrest height	600	9	Legs height	150
5	Armrest width	180	10	Sleeping area	-

SOFA 1

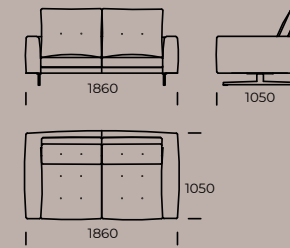

SOFA 2

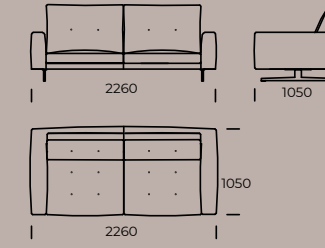

SOFA 3

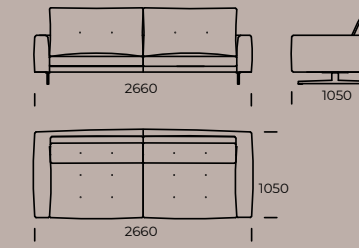

POUF

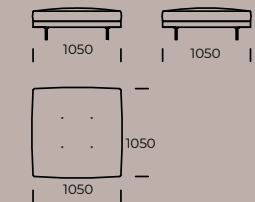

LEFT SEAT 1

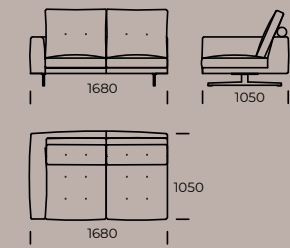

LEFT SEAT 2

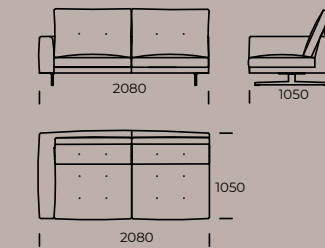

LEFT SEAT 3

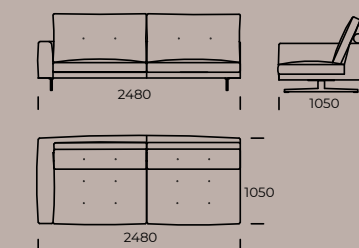

LEFT CHAISE LONGUE

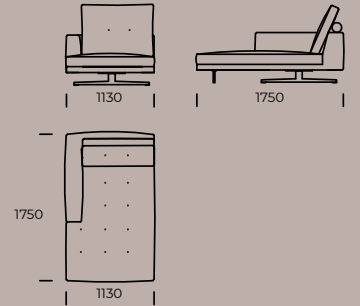

CORNER SEAT

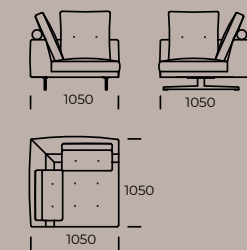

CUSHION

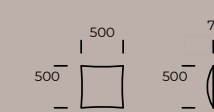

WIDE PILLOW - ON THE WHOLE LENGTH OF THE BACKREST



NARROW PILLOW - 8 CM NARROWER ON EACH SIDE

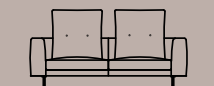

# PARADISE

\* All offered elements can be order in he left or right option

Technical information Sofa PARADISE (mm)					
1	Total high	870	5	Armrest width	80
2	Seat height	400	6	Total depth	990
3	Legs height	165	7	Seat depth	700
4	Armrest height	640	8	Sleeping area	-

SOFA 1

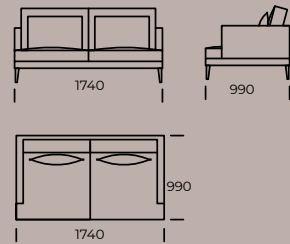

SOFA 2

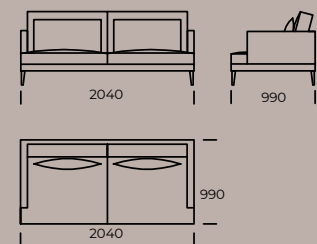

SOFA 3

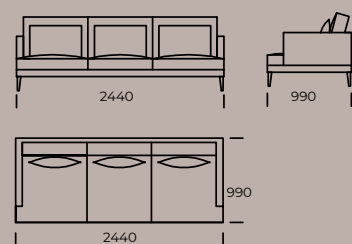

LEFT SEAT 1

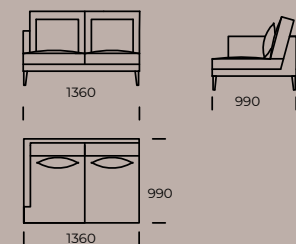

LEFT SEAT 2

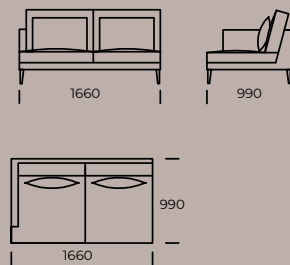

LEFT SEAT 3

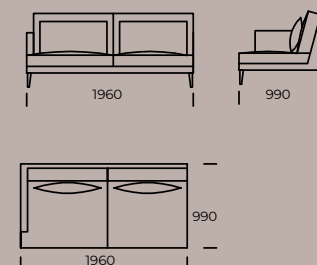

CENTRAL SEAT 1

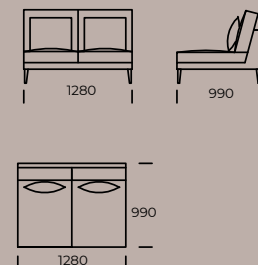

CENTRAL SEAT 2

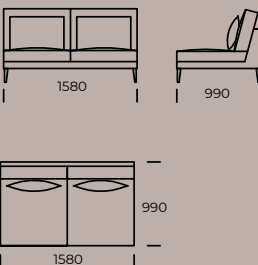

LEFT CHAISE LONGUE 1

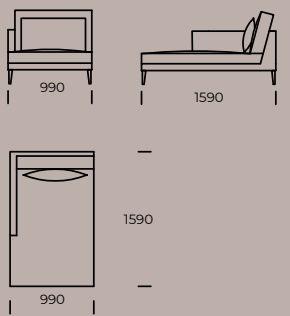

LEFT CHAISE LONGUE 2

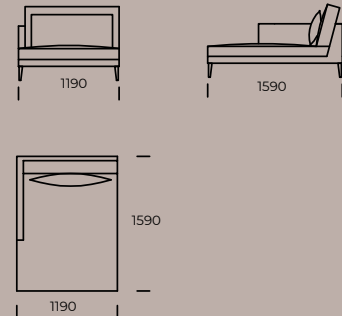

CORNER SEAT

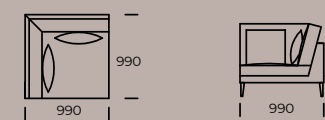

# RAKSA

\* All offered elements can be order in he left or right option

Technical information Sofa RAKSA (mm)					
1	Total high with cushion	950	6	Armrest width	200
2	Seat height	400	7	Total depth	1000/1200
3	Backrest height	740	8	Seat depth	800/1000
4	Armrest height	650	9	Seat depth with cushion	720/920
5	Sleeping area	-	10	Legs height	30

A1 CENTRAL SEAT A1

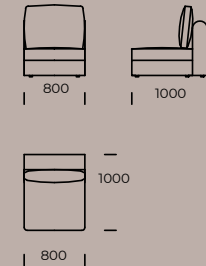

CENTRAL SEAT A2

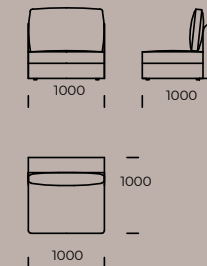

CENTRAL SEAT A3

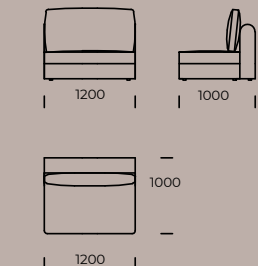

EXTERNAL ARMREST 1

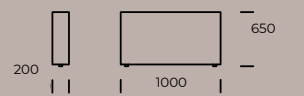

CENTRAL SEAT B1

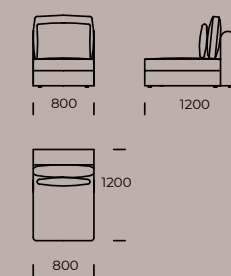

CENTRAL SEAT B2

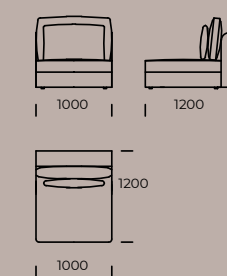

CENTRAL SEAT B3

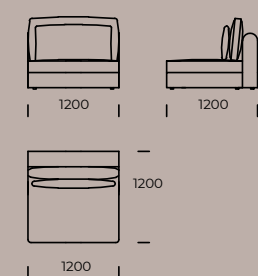

EXTERNAL ARMREST 1

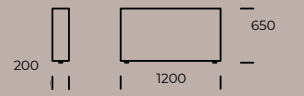

CENTRAL SEAT C1

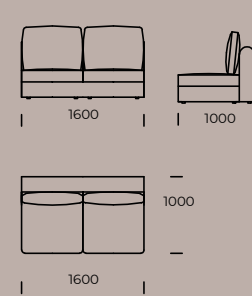

CENTRAL SEAT C2

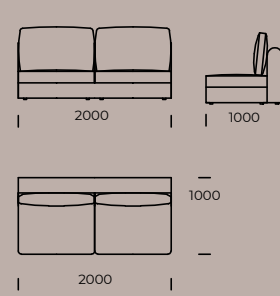

CENTRAL SEAT C3

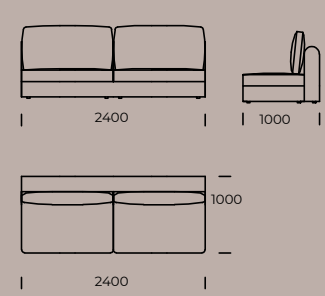
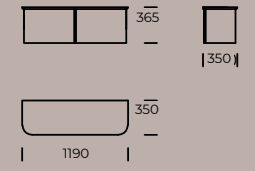

TABLE 1



TABLE 2





# RAKSA

\* All offered elements can be order in he left or right option

CENTRAL SEAT D1

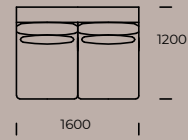
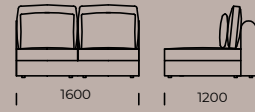

CENTRAL SEAT D2

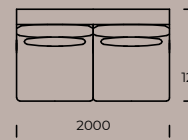
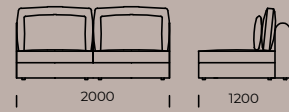

CENTRAL SEAT D3

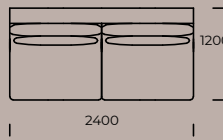
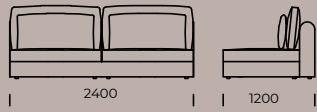

CORNER SEAT A

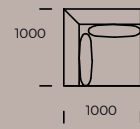
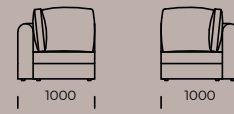

CORNER SEAT B

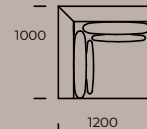
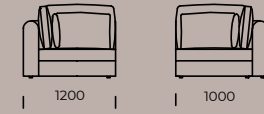

CORNER SEAT C

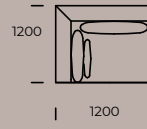
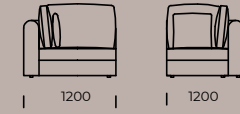

LEFT SEAT A1

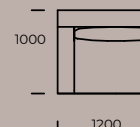
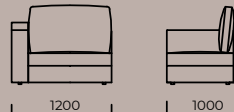

LEFT SEAT A2

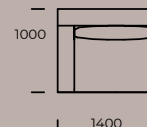
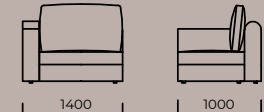

LEFT SEAT B1

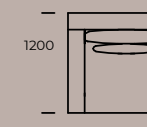

LEFT SEAT B2

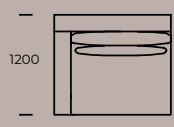

LEFT CHAISE LONGUE 1

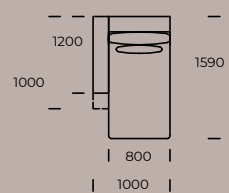
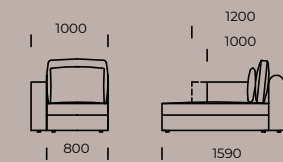

LEFT CHAISE LONGUE 2

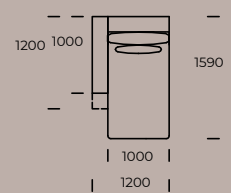
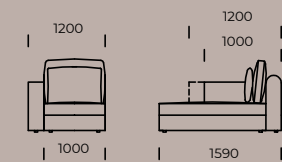

The chaise langu 1/2 is equipped with armrest A or B

# RAKSA

\* All offered elements can be order in he left or right option

LEFT COUCH A1

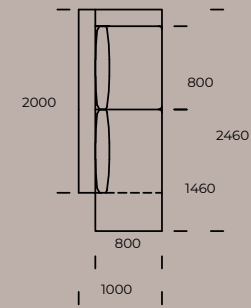
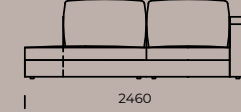

LEFT COUCH A2

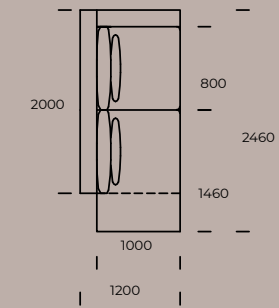
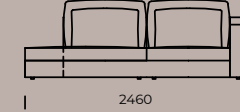

LEFT COUCH B1

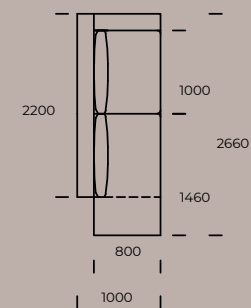
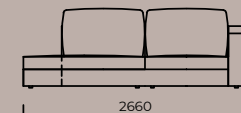

LEFT COUCH B2

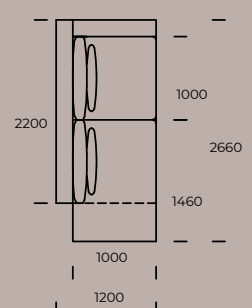
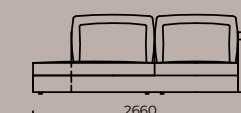

POUF 1

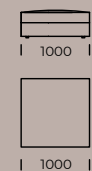

POUF 2

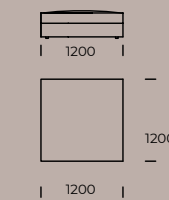

CUSHION

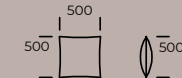

# UMO

\* All offered elements can be order in he left or right option

Technical information Sofa UMO (mm)					
1	Total high	~680	5	Armrest width	~250
2	Seat height	~380	6	Total depth	~1040
3	Armrest wide (h x w)	~680	7	Seat depth	650-700
4	Armrest narrow (h x w)	~470	8	Legs height	25

SOFA 1

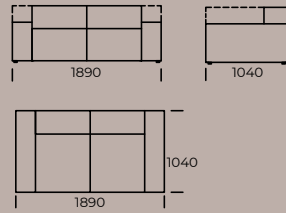

SOFA 2

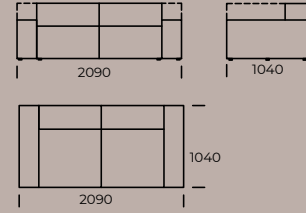

SOFA 3

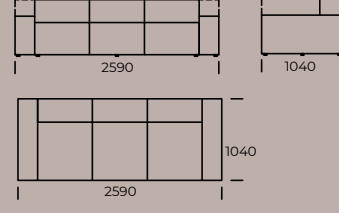

As a standard, the sofa has a low armrest (high armrest available)

LEFT SEAT A1

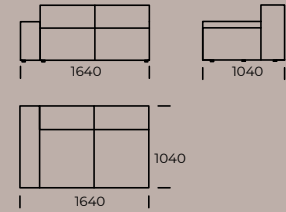

LEFT SEAT A2

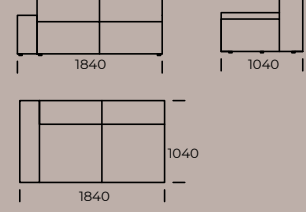

LEFT SEAT A3

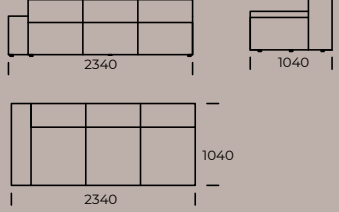

The Seat A1/A2/A3 seat is equipped with low armrest

LEFT SEAT B1

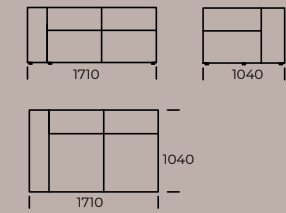

LEFT SEAT B2

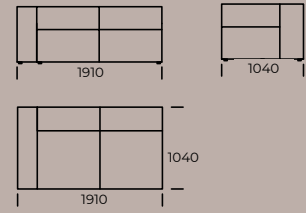

LEFT SEAT B3

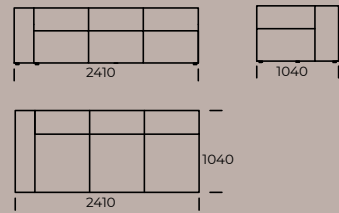

The B1/B2/B3 seat is equipped with high armrest

# UMO

\* All offered elements can be order in he left or right option

LEFT CHAISE LONGUE 1

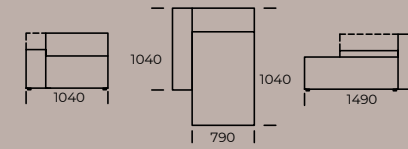

LEFT CHAISE LONGUE 2

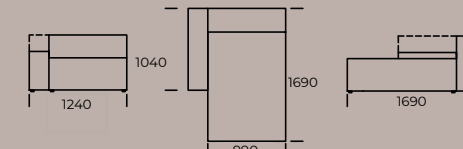

As a standard, the chaise longue has a low armrest (High armrest available)

CENTRAL SEAT A1

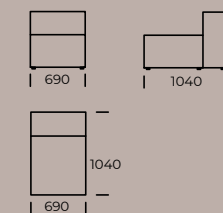

CENTRAL SEAT A2

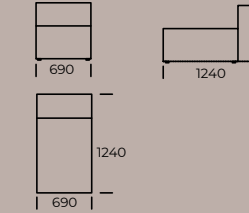

CENTRAL SEAT A3

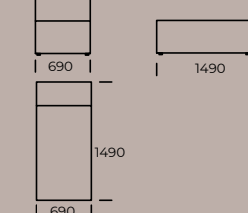

COUSION

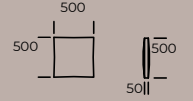

CENTRAL SEAT B1

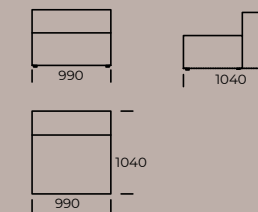

CENTRAL SEAT B2

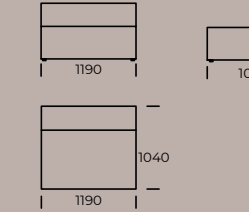

CENTRAL SEAT B3

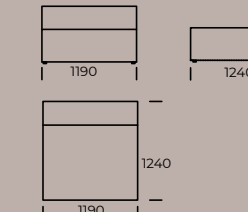

POUF 1

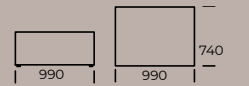

CENTRAL SEAT C1

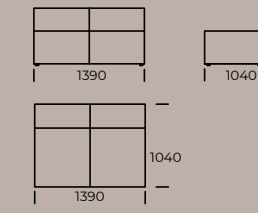

CENTRAL SEAT C2

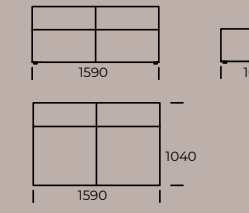

CENTRAL SEAT C3

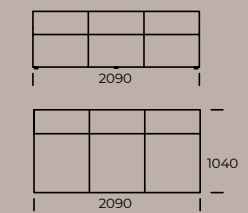

POUF 2



LEFT CORNER SEAT

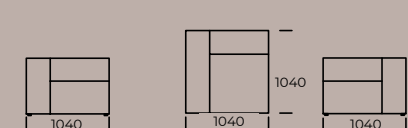

RIGHT BACKREST SOFA MODULE

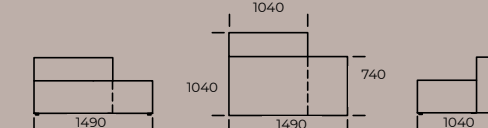

POUF 3





# WADI

# BEDS

Technical information Sofa WADI (mm)					
1	Total high	850	4	Total depth	1100
2	Seat height	380	5	Seat depth	730
3	Armrest width	270	6	Seat module width	210

SOFA 1

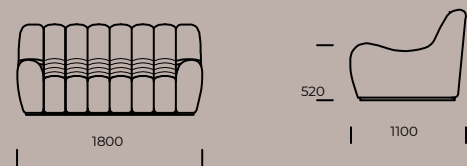

SOFA 2

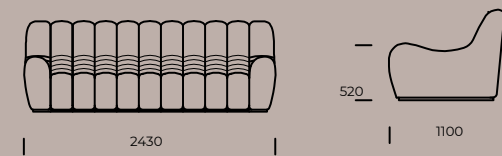

ARMCHAIR



POUF



COUSION



# ALIER

Technical information Bed ALIER (mm)					
1	Total high	940	7	Total width (1400x2000)	1550
2	Total depth	2200	8	Total width (1600x2000)	1750
3	Frame height	300	9	Total width (1800x2000)	1950
4	Legs height	20	10	Total width (2000x2000)	2150
5	Bedding container	yes	11	Depth mattress in frame	60
6	Mattres frame	yes	12	Mattres	no

# PIERO

Technical information Bed PIERO (mm)					
1	Total high	1000	7	Total width (1400x2000)	1900
2	Total depth	2150	8	Total width (1600x2000)	2100
3	Frame height	300	9	Total width (1800x2000)	2300
4	Legs height	240	10	Total width (2000x2000)	2500
5	Bedding container	no	11	Depth mattress in frame	10
6	Mattres frame	yes	12	Mattres	no

ALIER 1400x2000

ALIER 1600x2000

ALIER 1800x2000

ALIER 2000x2000

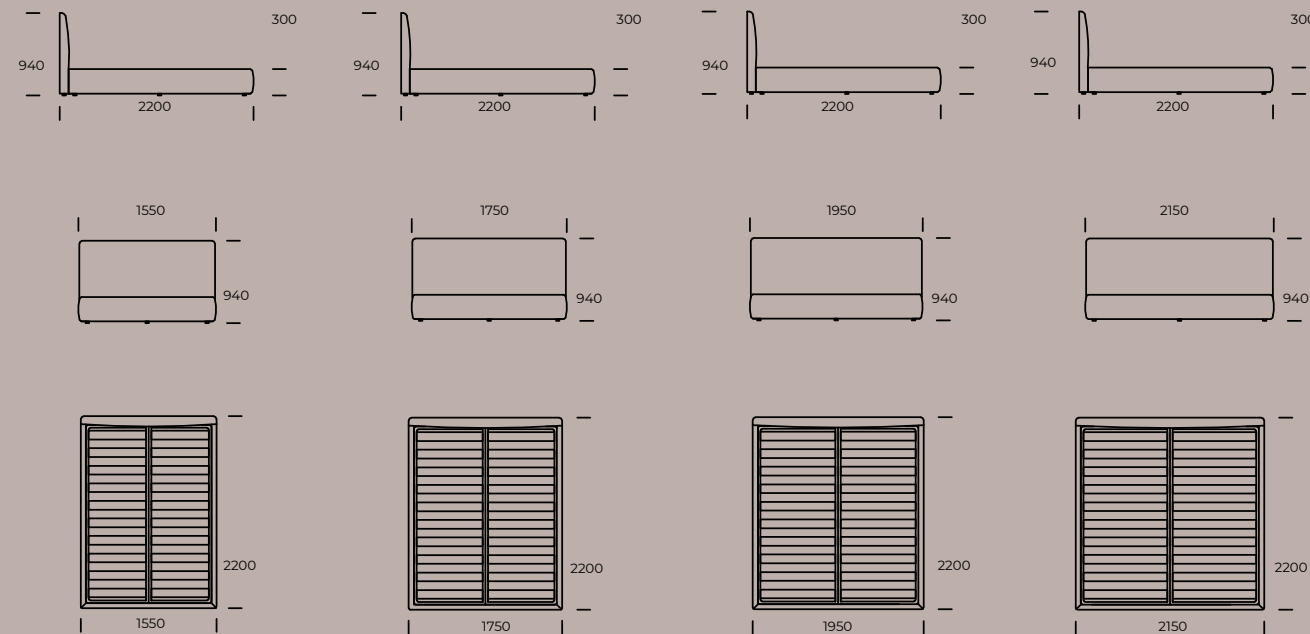

PIERO 1400x2000

PIERO 1600x2000

PIERO 1800x2000

PIERO 2000x2000

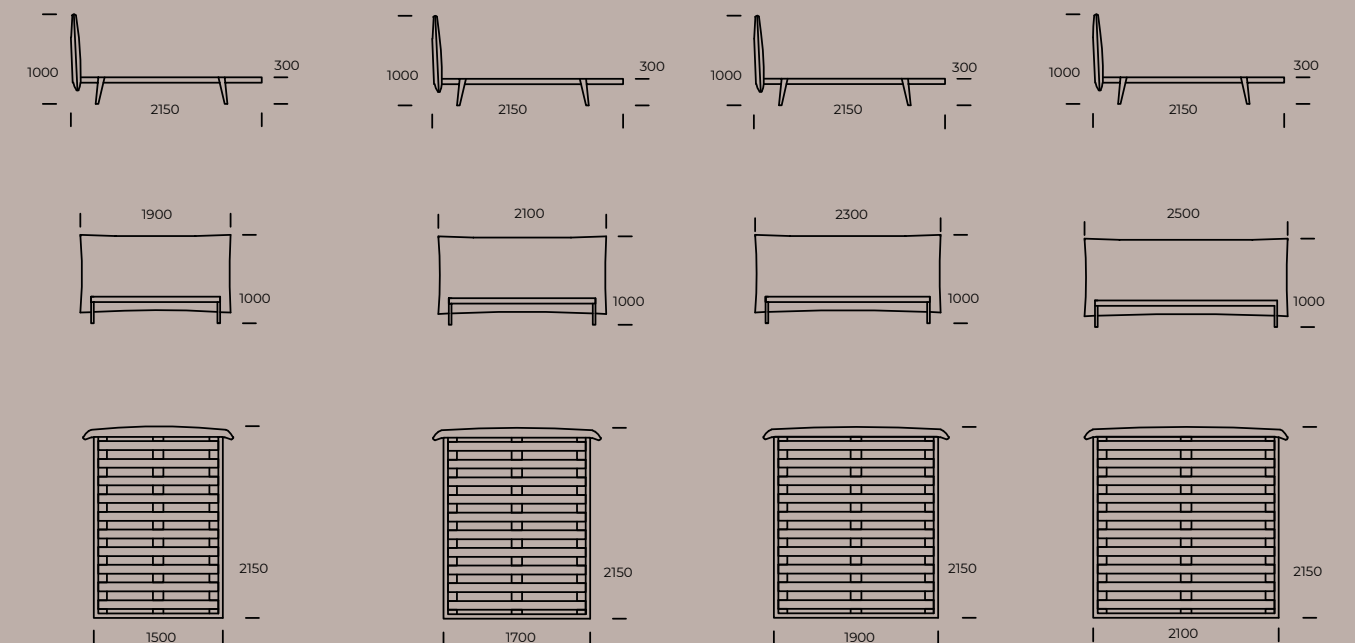



# PIANO

Technical information Bed PIANO (mm)					
1	Total high	1000	7	Total width (1400x2000)	1610
2	Total depth	2250	8	Total width (1600x2000)	1810
3	Frame height	380	9	Total width (1800x2000)	2010
4	Legs height	20	10	Total width (2000x2000)	2210
5	Bedding container	yes	11	Depth mattress in frame	60
6	Mattres frame	yes	12	Mattres	no

# SKORO

Technical information Bed SKORO (mm)					
1	Total high	900	7	Total width (1400x2000)	1640
2	Total depth	2350	8	Total width (1600x2000)	1840
3	Frame height	300	9	Total width (1800x2000)	2040
4	Legs height	170	10	Total width (2000x2000)	2240
5	Bedding container	no	11	Depth mattress in frame	50
6	Mattres frame	yes	12	Mattres	no

PIANO 1400x2000

PIANO 1600x2000

PIANO 1800x2000

PIANO 2000x2000

SKORO 1400x2000

SKORO 1600x2000

SKORO 1800x2000

SKORO 2000x2000

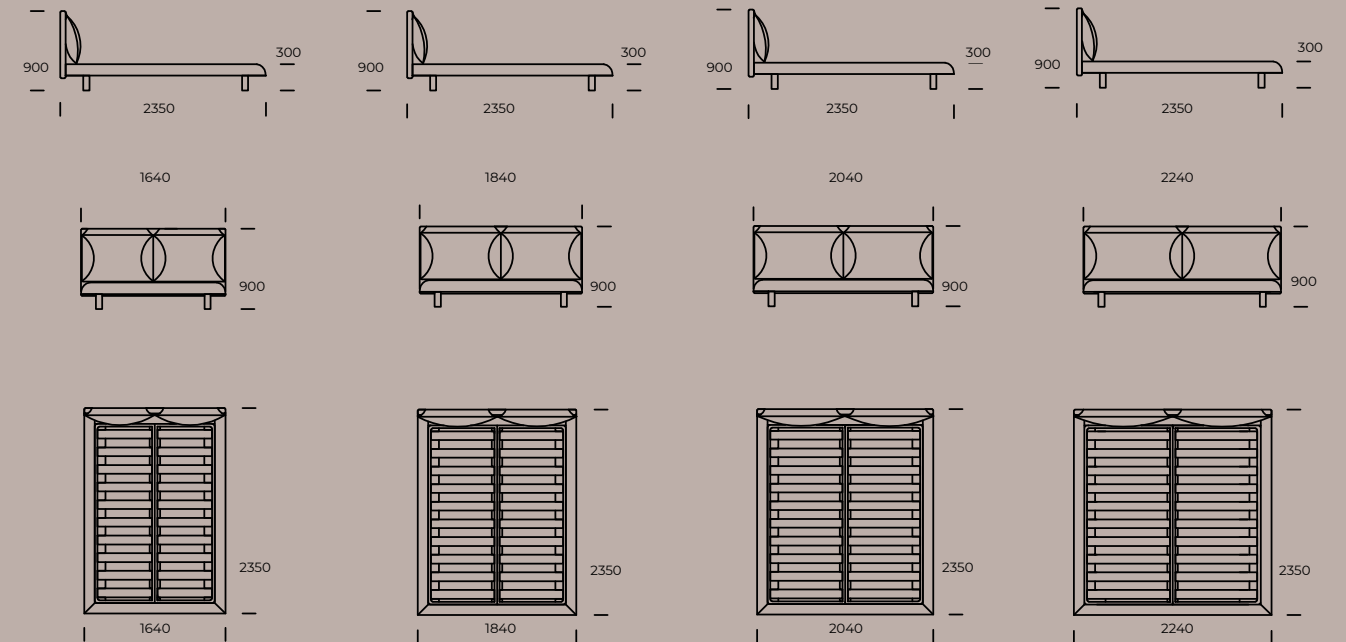
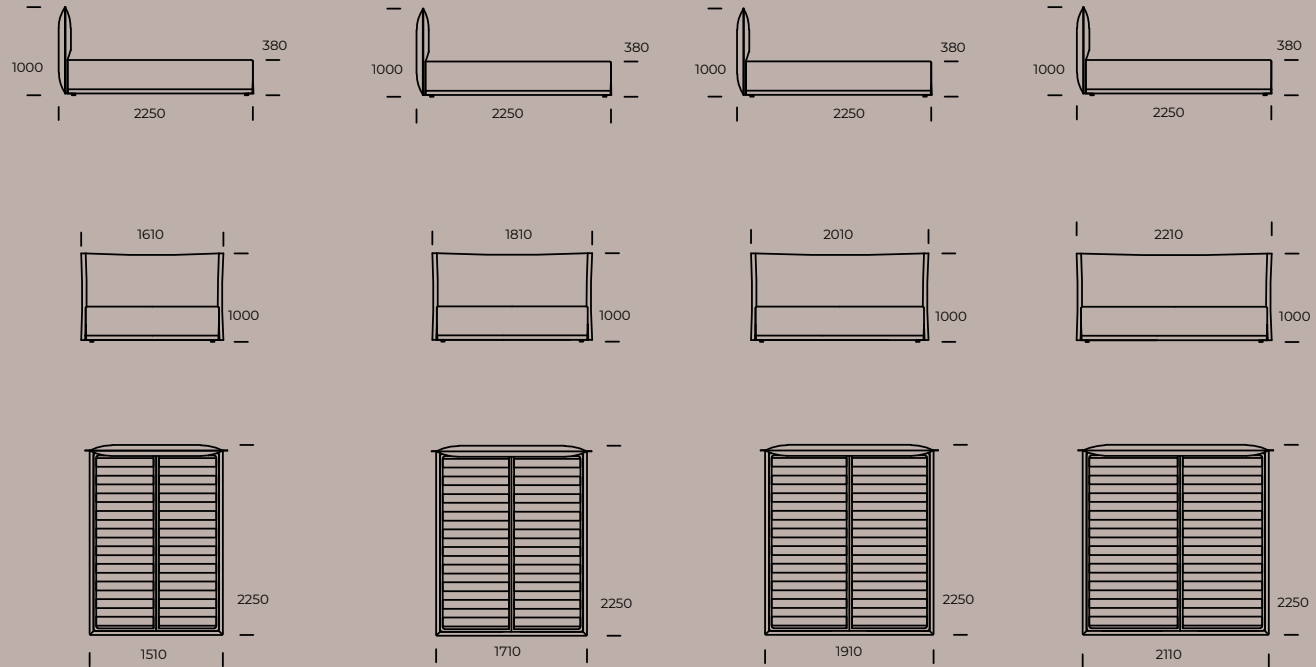

# VIOLET

Technical information Bed VIOLET (mm)					
1	Total high	1000	7	Total width (1400x2000)	1800
2	Total depth	2300	8	Total width (1600x2000)	2000
3	Frame high	300	9	Total width (1800x2000)	2200
4	Legs height	170	10	Total width (2000x2000)	2400
5	Bedding container	no	11	Depth mattress in frame	50
6	Mattres frame	yes	12	Mattres	no

# UMO

Technical information Bed UMO (mm)					
1	Total high	810	7	Total width (1400x2000)	1900
2	Total depth	2450	8	Total width (1600x2000)	2100
3	Frame high	350	9	Total width (1800x2000)	2400
4	Legs height	20	10	Total width (2000x2000)	2600
5	Bedding container	yes	11	Depth mattress in frame	110
6	Mattres frame	yes	12	Mattres	no

VIOLET 1400x2000

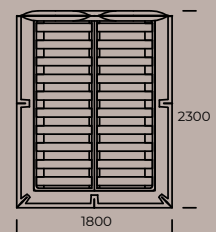
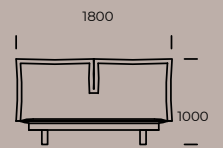
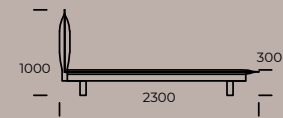

VIOLET 1600x2000

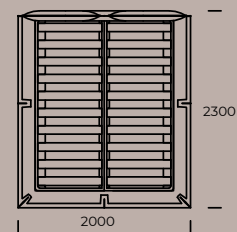
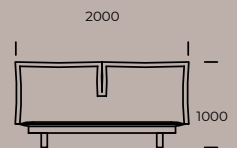
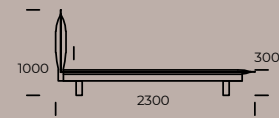

VIOLET 1800x2000

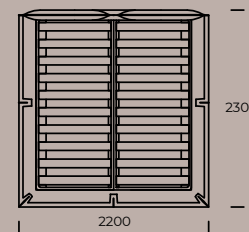
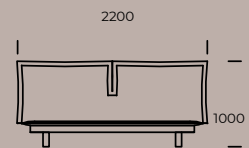
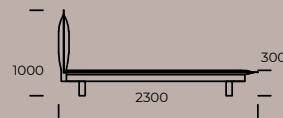

VIOLET 2000x2000

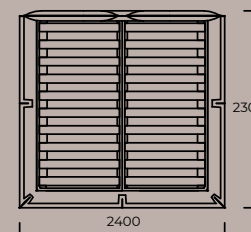
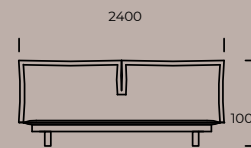
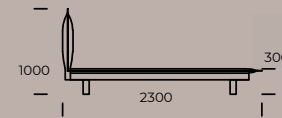

UMO 1400x2000

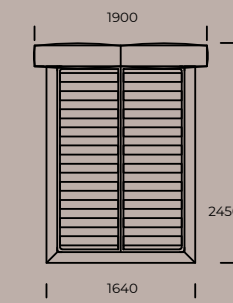
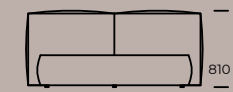
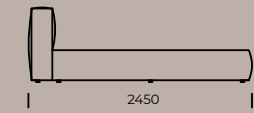

UMO 1600x2000

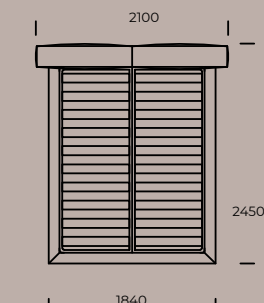
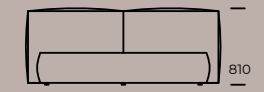
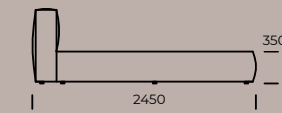

UMO 1800x2000

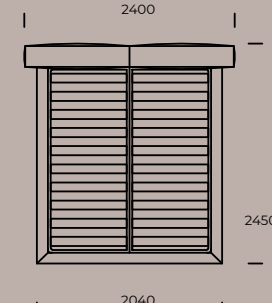
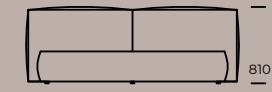
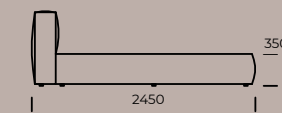

UMO 2000x2000

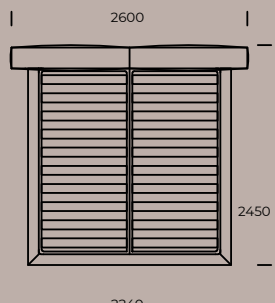
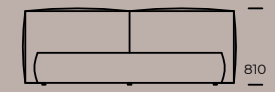
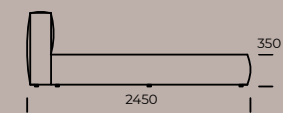



# ARMCHAIRS

## MUST

Technical information Chair MUST (mm)		
1	Total high	880
2	Seat height	-
3	Total depth	550
4	Seat depth	-
5	Seat depth with cushions	-
6	Legs height	-

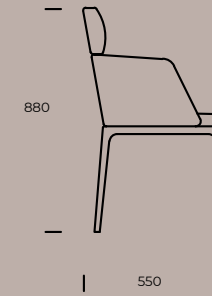

## TUPAK

Technical information Armchair TUPAK (mm)		
1	Total high	860
2	Seat height	450
3	Total depth	680
4	Seat depth	515
5	Seat depth with cushions	385
6	Legs height	330

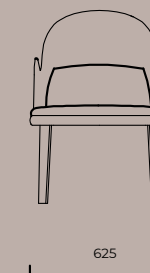

# PYORA I

Technical information Armchair PYORA I (mm)		
1	Total high	800
2	Seat height	400
3	Total width	760
4	Seat depth	700
5	Cushion	500x600
6	Legs height	200

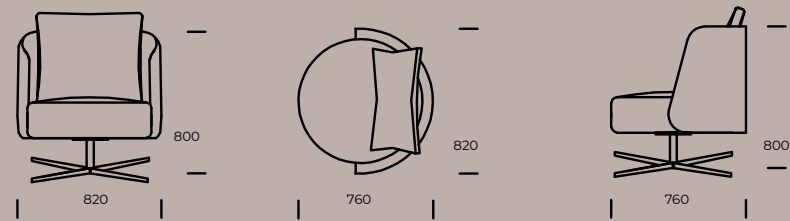

# UNI

Technical information Armchair UNI (mm)		
1	Total high	620
2	Seat height	380
3	Total width	900
4	Seat depth	480
5	Cushion	-
6	Legs height	80



# PYORA II

Technical information Armchair PYORA II (mm)		
1	Total high	800
2	Seat height	400
3	Total width	760
4	Seat depth	700
5	Cushion	500x600
6	Legs height	60

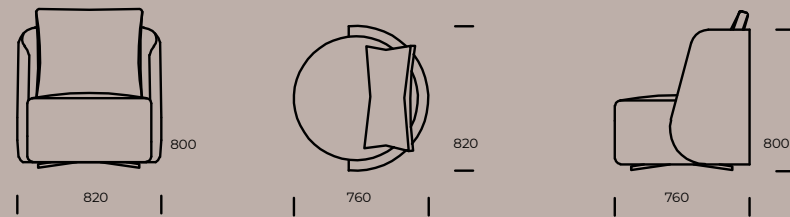



# POUFS

## BUNNY GUYS

Technical information Pouf BUNNY GUYS (mm)		
1	Total high	1300
2	Total high	420
3	Total width	570
4	Seat depth	460
5	Cushion	-
6	Legs height	25

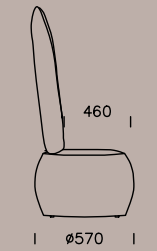
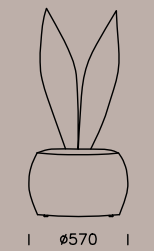

## MODO

Technical information Pouf MODO (mm)		
1	Total high	1000
2	Total width	1100
3	Total depth	900

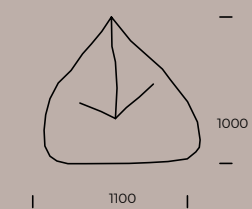
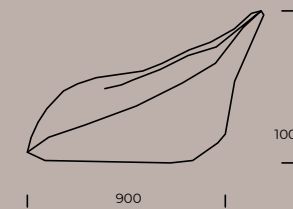

# UMO

Technical information Pouf UMO - folding (mm)		
1	Total high	430
2	Seat height	430
3	Total depth	750
4	Seat width	900
5	Sleeping area	1920x800

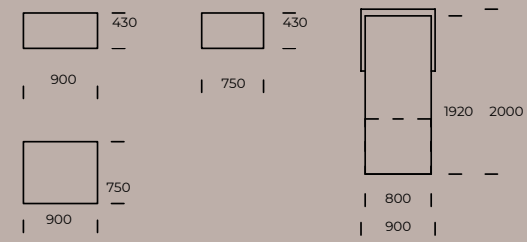

# TABLES



# FERRO

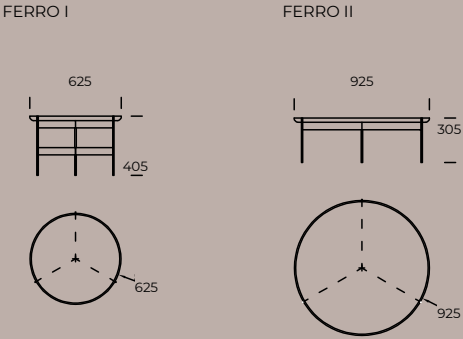

# FEZA

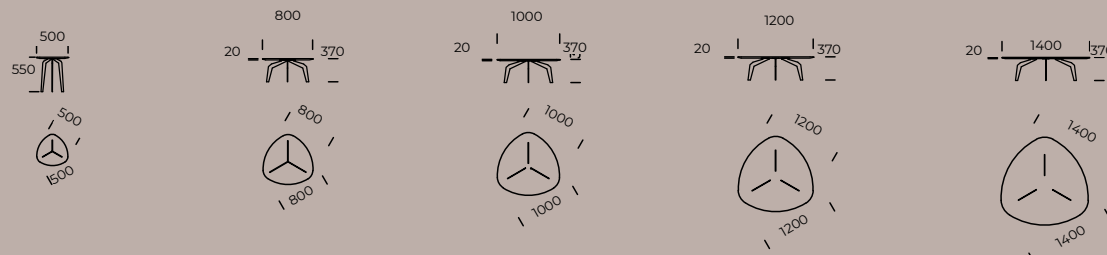
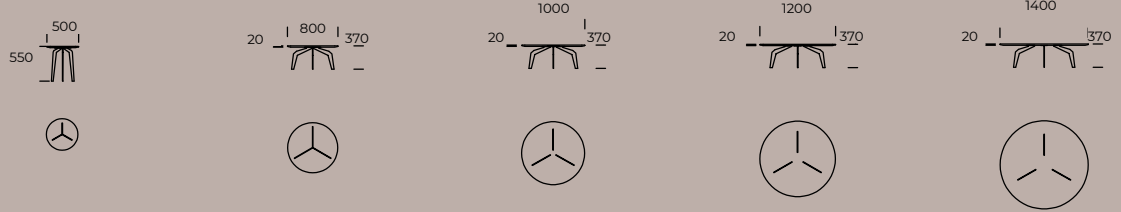
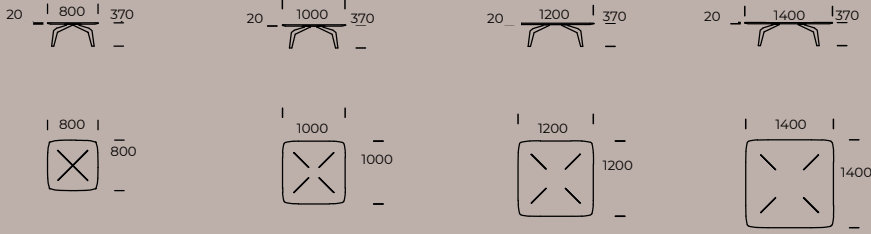

# FLESIA

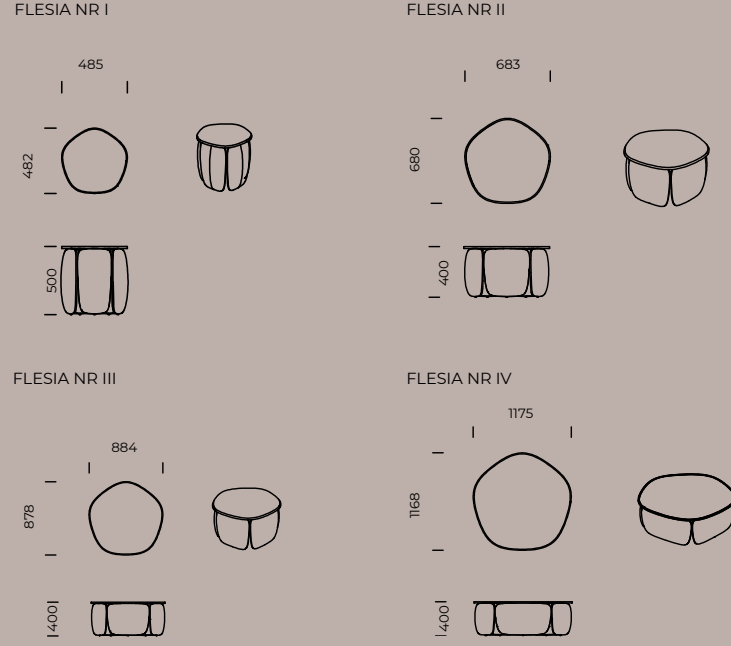

# MINUS

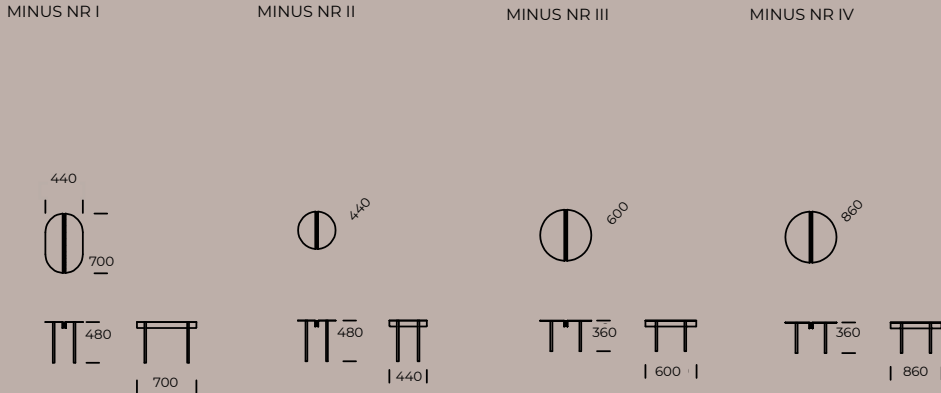

# NATO

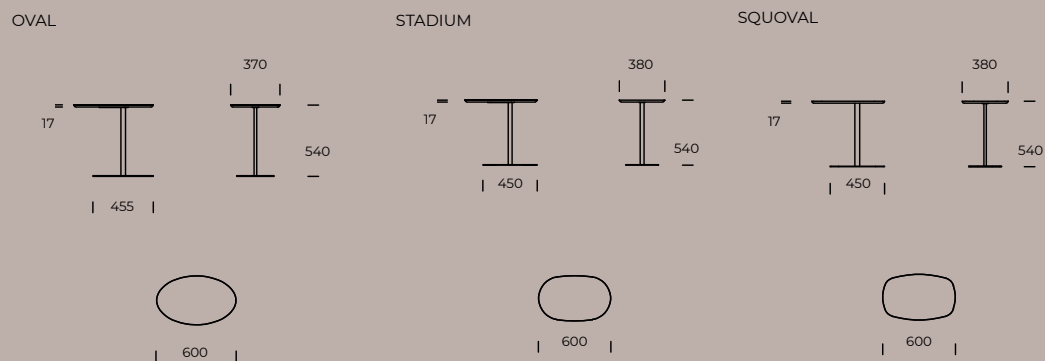

# OTHERS

## OO

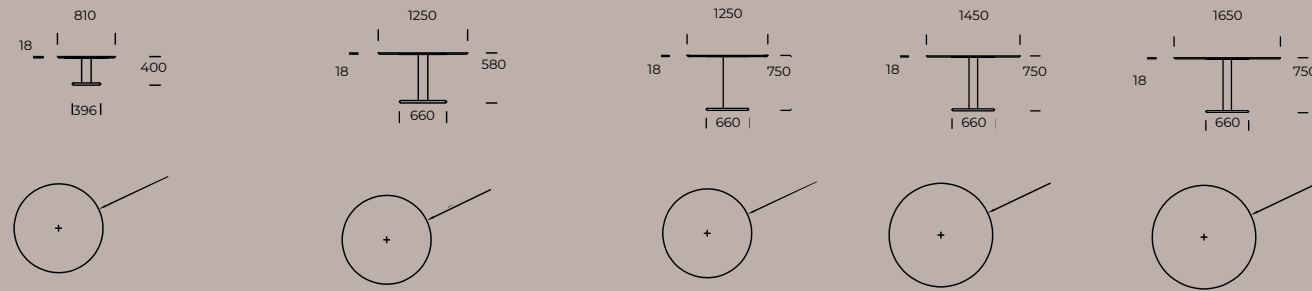

## ROOTS

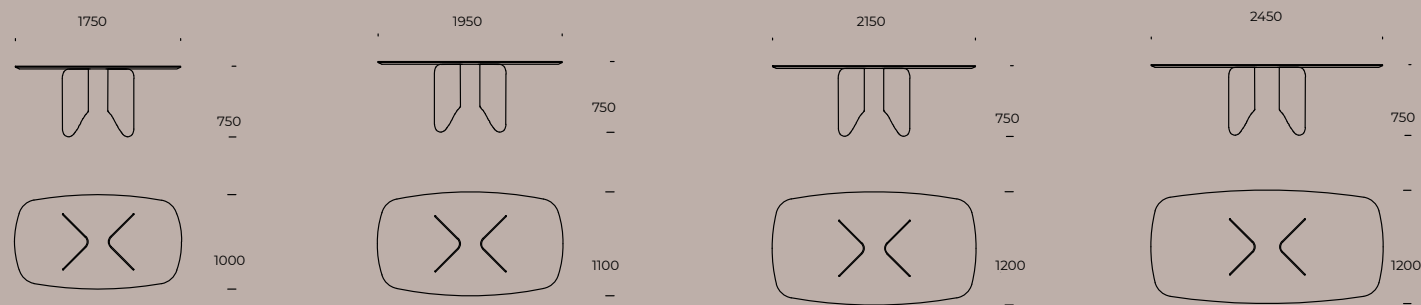



# BAMBA

PLANT STAND 01

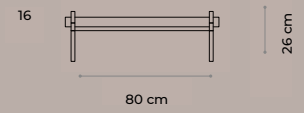

PLANT STAND 02

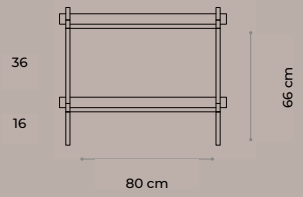

PLANT STAND 03

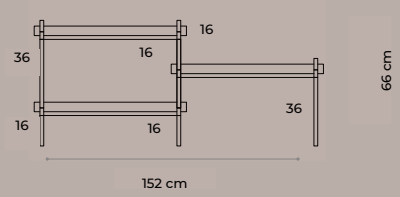

SLIDEBOARD 01

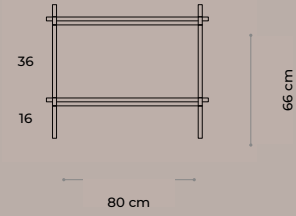

SLIDEBOARD 02

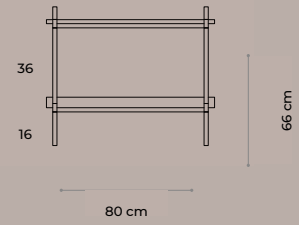

SLIDEBOARD 03

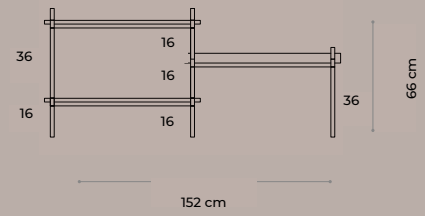

SLIDEBOARD 04

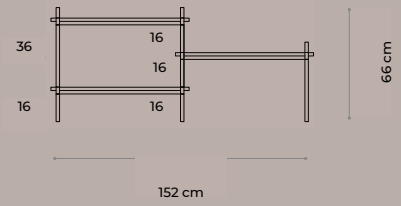

SLIDEBOARD 05

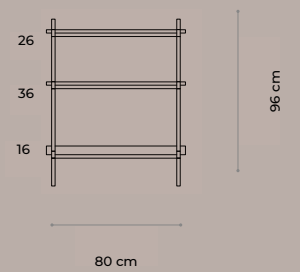

SLIDEBOARD 06

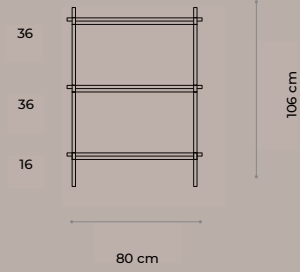

SLIDEBOARD 07

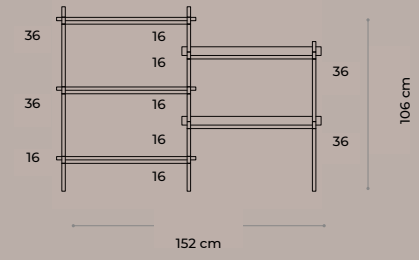

SLIDEBOARD 08

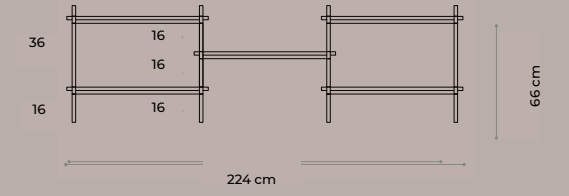

SLIDEBOARD 09

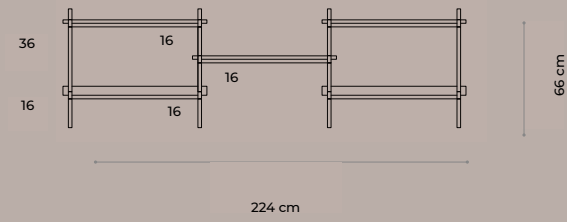

SLIDEBOARD 10

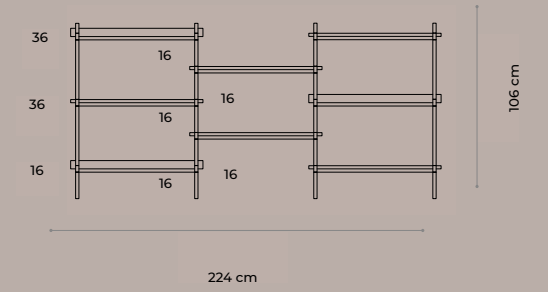

BOOKCASE 01

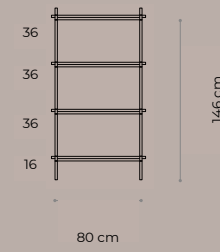

BOOKCASE 02

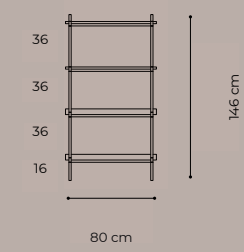

BOOKCASE 03

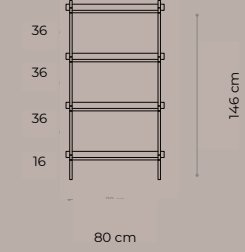

BOOKCASE 04

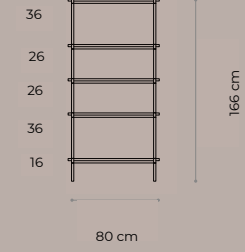

BOOKCASE 05

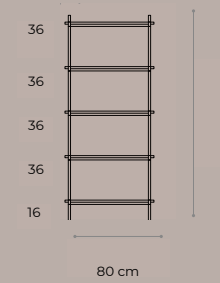

BOOKCASE 06

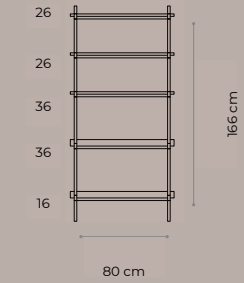

BOOKCASE 07

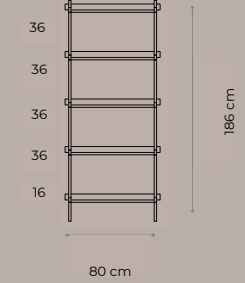

BOOKCASE 08

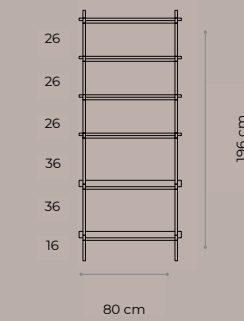

# SAD

DISPLAY 01

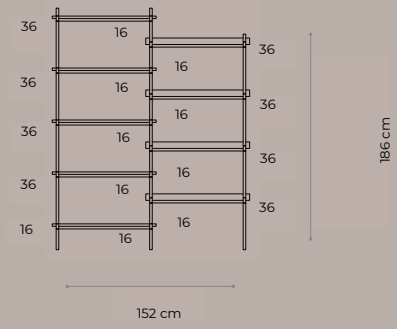

DISPLAY 02

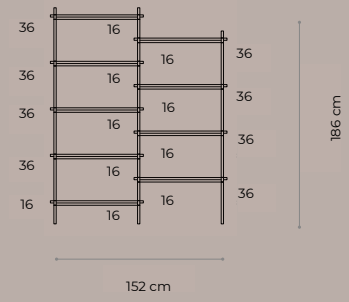

DISPLAY 03

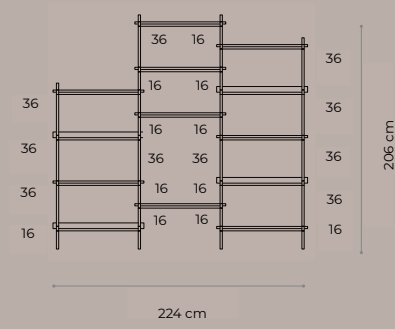

DISPLAY 04

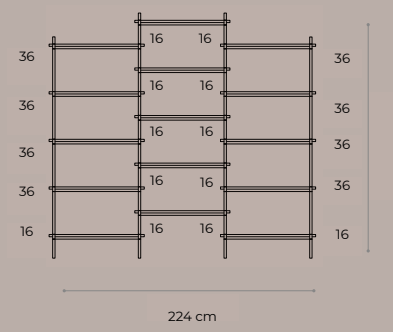

DISPLAY 05

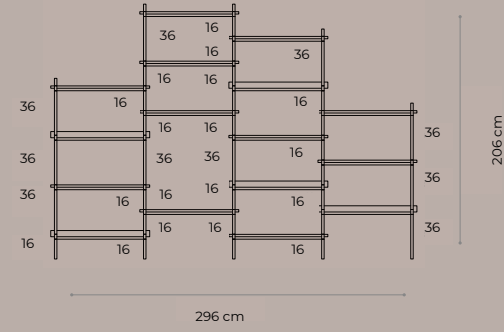

Technical information SAD (mm)		
1	Diameter	60,80,100
2	Total depth	52



52



60



80



100

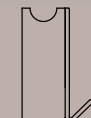

52

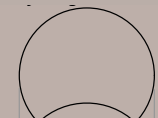

100



# COOPERATION

## GRAPHIC DESIGN

Dział graficzny Nobonobo

## PHOTOGRAPHS

Yassen Hristov  
Bartek Bieliński Fotografia  
Mleko Living  
Marek Swoboda Fotografia  
Ewa Kania  
Tomasz Miotk Fotografia  
Paweł Martyniuk  
Marcin Grabowiecki  
Fotomohito  
Studio Prototypownia Alla Boroń  
*Elena Penyaz*

## DESIGNERS

Chris Stanfel ( Flesia )  
Dmitry Kozinenko ( Minus )  
Ezio Pescatori ( Sad )  
Juanny Barcelò Borges (Maxxo)  
Katarzyna Załuska, Michal Załuski / Mleko Living ( Bamba )  
Nelson de Araújo (Margo, Roots)  
Sergey Murko (Bunny Guys)  
Stas Litvinov (Uni)  
Tomek Rygalik / Studio Rygalik ( Wadi, Raksa, Tupak, Nato, Oo )

## INTERIOR DESIGN

Architektura wnętrz ANNA THUROW  
MOZAYKA nieruchomości i projektowanie  
MANUKA Pracownia Projektowa  
POLALA Studio  
KUBIENIEC & DŁUGOSZ  
DOBRY Układ Sandra Białkowska  
POCO Design, Patrycja Suszek-Rączkowska  
ARCHITASTE Paweł Ślęzak  
KOŁASA Concept  
Anna SERAFIN Architektura wnętrz

## PRINT

Drukarnia Beltrani S.J.  
Śliwkowa 1,  
31-982 Kraków

## PRINTED ON PAPER

Arctic Volume Ivory 150g  
Maestro 120g  
Van Heek Textiles - Halfinnen Dark

## DISTRIBUTION

Papierowy Dizajn  
Europapier Sp. z o. o.

## PUBLISHER

Kaza design sp. z o.o.  
ul. Żywiecka 212,  
34-325 Łodygowice

# BE ONLINE

All products shown are originals. Kaza design sp. z o. o. reserves the right to designs, patents and all other creative and original brand elements. Copying the material, either in whole or in part, without Kaza Design's sp. z o. o. prior consent is prohibited.

The manufacturer reserves the right to modify product colours, dimensions and functionalities. The colours of products in photographs and in print may vary from the actual products.

Instagram



Facebook



Need an online catalog?

Visit our website to download it in Polish, English, German and French.





**Kaza Design sp. z o.o.**

Ul. Żywiecka 212  
34-325 Łodygowice  
NIP 553 248 68 91





